

May 30, 1950

D. KAHN

2,509,234

FOUNTAIN PEN CAP

Filed Dec. 28, 1945

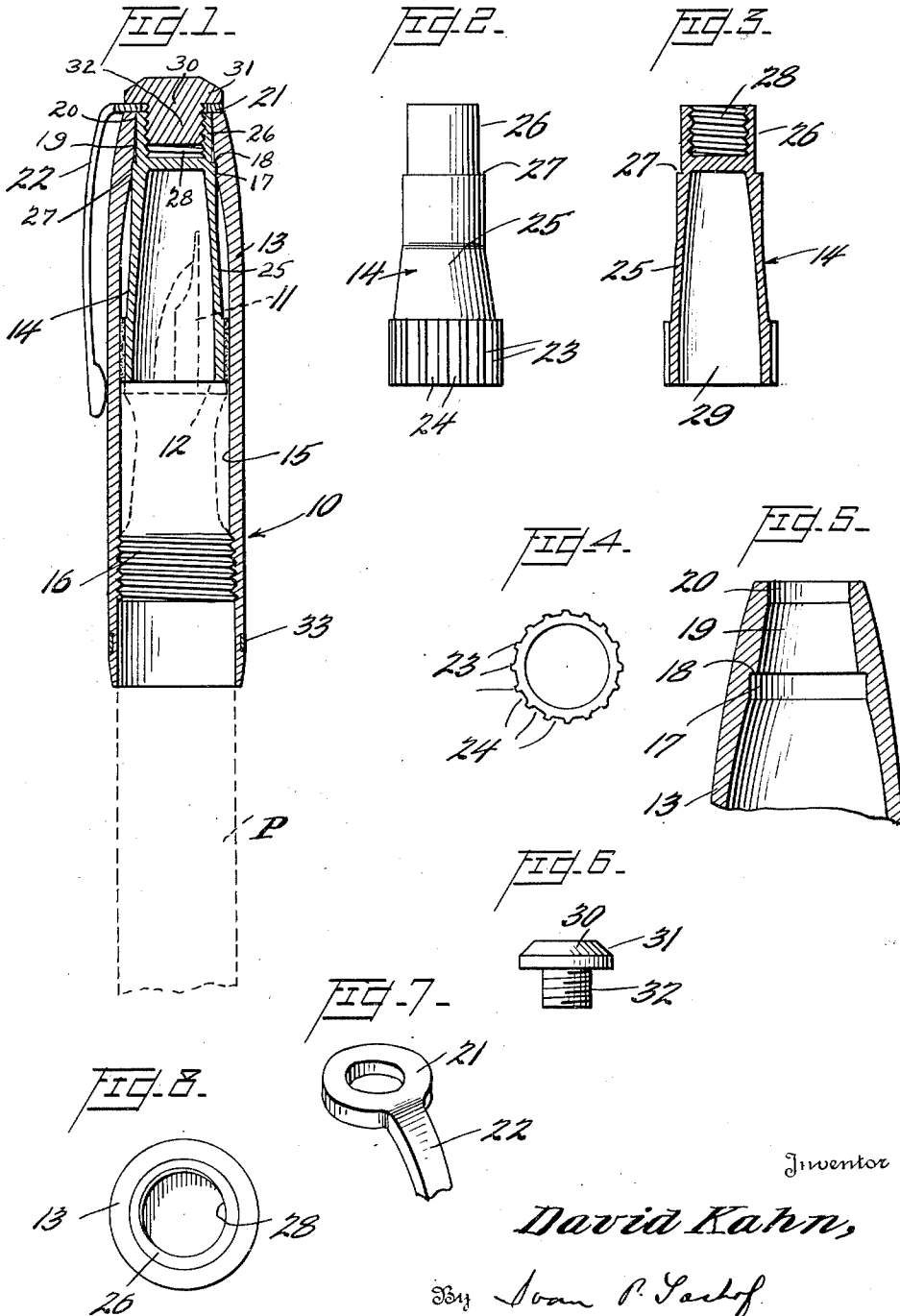

Inventor

David Kahn,

By Ivan P. Gostof

Attorney

UNITED STATES PATENT OFFICE

2,509,234

FOUNTAIN PEN CAP

David Kahn, Englewood, N. J., assignor to David Kahn, Inc., North Bergen Township, Hudson County, N. J., a corporation of New Jersey

Application December 28, 1945, Serial No. 637,556

7 Claims. (Cl. 120—42.01)

1

The present invention relates to a fountain pen. More particularly, the invention relates to a fountain pen provided with a novel cap capable of securely holding the clip and of effectively sealing the pen when the cap is secured thereon.

Fountain pen caps are usually made of relatively thin plastic material and considerable difficulty has been encountered heretofore in securing the clip to the cap, and in providing a cap which will effectively seal the pen when the cap is screwed thereupon. It is well known to provide inner sleeves or inner caps which will provide a shoulder cooperating with the end of the barrel in order to seal the pen. However, these inner caps which are generally held in place by means of a suitable cement, are prone to break away from the material of the cap itself. In this type of fountain pen cap, a plug member is screwed into the end thereof in order to retain a grip, and considerable difficulty has been encountered in providing threads in the cap to receive the plug member. During the threading of the cap, in many cases, the inner cap or sleeve tends to become loose and this is true even though the inner cap or sleeve is held by a suitable cementing medium.

It is one of the objects of the present invention, therefore, to provide a fountain pen cap member with a novel inner cap or sleeve capable of receiving the plug member for retaining the clip on the cap.

Another object of the present invention is to provide a fountain pen cap having an inner cap or sleeve member having means thereon for preventing relative rotation of the inner cap and the cap proper.

Still another object of the present invention is to provide an inner cap member constructed to be wedged into the outer cap member and securely held therein, and further provided with a series of grooves capable of holding cement or other uniting material.

A fourth object of the present invention is to provide an inner cap member for a fountain pen cap having formed therein opposed bores, one of said bores being adapted to receive a pen nib, and the other bore being provided with threads for receiving a plug member which serves to retain a clip on the cap.

A fifth object of the present invention is to provide a cap and inner cap structure wherein the inner cap is adapted to become firmly wedged within the outer cap.

A sixth object of the present invention is to provide an outer cap and inner cap assembly for

2

a fountain pen wherein a pair of cooperating shoulders on the inner cap and outer cap serve to definitely position the inner cap within the outer cap so that the top of the inner cap will be flush with the top of the outer cap when said members are assembled.

A seventh object of the present invention is to provide inner and outer cap members so constructed as to form a firm seat for a portion of a clip member when the same is mounted on the cap.

Other objects and advantages of the present invention will become apparent from the following description taken in connection with the figures of the drawing, wherein:

Fig. 1 is a vertical section of a fountain pen cap and inner cap assembly according to the present invention;

Fig. 2 is an elevation of the inner cap member;

Fig. 3 is a vertical section of the inner cap member;

Fig. 4 is a bottom plan view of the inner cap member;

Fig. 5 is an enlarged vertical section of the outer cap;

Fig. 6 is a detail of the threaded plug member;

Fig. 7 is a perspective detail of the upper end portion of the clip; and

Fig. 8 is a top plan view of the cap assembly with the plug and clip removed.

Referring to the figures of the drawing, and particularly Fig. 1, a fountain pen cap and clip assembly is indicated in general at 10. The cap 10 is adapted to receive a fountain pen which is indicated in dotted lines and designated by the reference character P. The fountain pen P is provided with a usual nib 11 and is adapted to be threadedly received within the cap in the usual manner so that the end of the barrel indicated at 12, abuts a shoulder within the cap for effectively sealing the pen. The fountain pen cap 10 consists of two principal parts; an outer cap member 13, and an inner cap member 14. The outer cap member 13 is provided with a bore 15, having the outer threads 16 formed therein for threadedly receiving the fountain pen barrel. The bore 15 tapers inwardly slightly at its upper end and terminates in a counter bore 17 which serves to provide a shoulder 18 for a purpose to be hereinafter described. Above the shoulder 18 a somewhat tapered bore 19 is provided which terminates in a relatively straight bore 20, as shown particularly in Fig. 5 of the drawings. The inner cap or sleeve member 14 is fitted within the bores just described so that the upper end of the inner cap

3

or sleeve member 14 is flush with the upper end of the outer end of the cap 13, the two caps together serving to form a seat for a ring member 21 forming the upper part of a clip 22. The inner sleeve member 14 is provided with a series of ribs 23 forming a series of grooves 24, for a purpose to be hereinafter set forth.

Above the ribs the inner cap member 14 is provided with a generally tapered portion 25 terminating in a reduced end portion 26 thus forming a shoulder indicated at 27.

As shown particularly in Fig. 3, the inner cap member or sleeve 14 is also provided with a pair of opposed bores 28 and 29, the lower of which, the bore 29, is adapted to receive the pen nib as shown in Fig. 1, and the bore 28 is provided with threads to threadedly receive a plug 30, best shown in Fig. 6.

The plug 30 is provided with a button 31 and a reduced threaded portion 32. The cap 10 may also be provided with an ornamental ring of metal indicated at 33. The inner and outer cap are each preferably integrally moulded of a suitable plastic material such as cellulose nitrate, cellulose acetate, or other plastic materials well known in the pen art.

The inner and outer cap members are preferably assembled by coating the grooves 24 with a suitable cement, such as a solvent solution of cellulose acetate or cellulose nitrate, and thereafter the inner cap or sleeve member is driven into the outer cap or sleeve member until the shoulder 27 abuts the shoulder 18. Preferably the relatively straight portion or bore 20 at the upper end of the outer cap is initially slightly smaller than the reduced portion 26 of the inner cap. Therefore, during the assembly of the inner cap and the outer cap a firm friction seat is established at the upper end of the inner and outer cap members. In addition, the portion provided with ribs 23 is slightly larger than the straight inner diameter of the bore 15 so that the ribs are firmly wedged against the inner bore of the cap. The ribs, in addition to providing the grooves 24 for receiving the cement therefore, also provide a means for preventing relative rotation between the inner and outer cap members. After the inner and outer cap members are thus assembled, the ring portion 21 of the clip 22 is seated upon the upper surface of the assembled cap and screw threaded portion 32 of the plug 30 is then threaded into the screw threaded bore 28 of the cap. The action of the plug, therefore, serves to adequately firmly hold the inner cap within the outer cap.

It is to be noted that the inner and outer cap together form a relatively wide surface at the upper end of the cap assembly. The ring member 21 can therefore be made much wider than those conventional in the art, and the screw threaded portion 32 is therefore relatively smaller. Since the ring member and clip are usually stamped from relatively thin metal, this has been found to greatly reduce the breakage during the manufacture of the clip.

What is claimed is:

1. In a fountain pen, including a barrel and a nib protruding from the lower end of said barrel, a tubular cap member having a bore of generally cylindrical shape at its lower end merging into an inwardly tapering bore portion at its upper end, a sleeve within said cap member having a first portion within the cylindrical portion of the bore, and a second portion within the tapering portion of the bore, means to prevent relative rotation of said sleeve and cap one with respect

4

to the other, a pair of cooperating shoulders on the sleeve and cap members limiting the longitudinal movement of the sleeve and cap member and aligning the upper end of the sleeve with the upper end of the cap member, opposed bores in said sleeve, the lower bore being arranged within the cap to receive the pen nib and the lower end of the sleeve being positioned within the cap to form a shoulder cooperating with the end of the pen barrel to form a seal, the upper end of the cap and the sleeve forming a flush bearing surface, said cooperating sleeve and cap shoulders being disposed adjacent and below said flush surface, clip-retaining means, means within the upper bore of said sleeve for receiving and securing therein said clip-retaining means, and a clip provided with a laterally extending flat ring portion mounted on said bearing surface and clamped in place by said clip-retaining means.

2. In a fountain pen, including a barrel and a nib protruding from the lower end of said barrel, a tubular cap member having a bore of generally cylindrical shape at its lower end merging into an inwardly tapering bore portion at its upper end, a sleeve within said cap member having a first portion within the cylindrical portion of the bore, and a second portion within the tapering portion of the bore, a plurality of spaced longitudinally extending ribs on the exterior of said first portion of the sleeve forming cement-retaining grooves adjacent the bore wall, cement in said grooves, said ribs and cement preventing relative rotation of said sleeve and cap one with respect to the other, a pair of cooperating shoulders on the sleeve and cap members limiting the longitudinal movement of the sleeve and cap member and aligning the upper end of the sleeve with the upper end of the cap member, opposed bores in said sleeve, the lower bore being arranged within the cap to receive the pen nib, the upper ends of the cap and the sleeve forming a flush bearing surface, said cooperating sleeve and cap shoulders being disposed adjacent and below said flush surface, clip-retaining means, means within the upper bore of said sleeve for receiving and securing therein said clip-retaining means, and a clip provided with a laterally extending flat ring portion mounted on said bearing surface and clamped in place by said clip-retaining means.

3. In a fountain pen, including a barrel and a nib protruding from the lower end of said barrel, a tubular cap member having a bore of generally cylindrical shape at its lower end merging into an inwardly tapering bore portion at its upper end, a sleeve within said cap member having a first portion within the cylindrical portion of the bore, and a second portion within the tapering portion of the bore, means to prevent relative rotation of said sleeve and cap one with respect to the other, a pair of cooperating shoulders on the sleeve and cap members limiting the longitudinal movement of the sleeve and cap member, and aligning the upper end of the sleeve with the upper end of the cap member, opposed bores in said sleeve, the lower bore being arranged within the cap to receive the pen nib, the upper end of the cap and the sleeve forming a flush bearing surface, said cooperating sleeve and cap shoulders being disposed adjacent and below said flush surface, clip-retaining means, threaded means within the upper bore of said sleeve for receiving and securing therein said clip-retaining means, and a clip provided with a laterally extending flat ring portion mounted on said bear-

ing surface and clamped in place by said clip-retaining means.

4. In a fountain pen, including a barrel and a nib protruding from the lower end of said barrel, a tubular cap member having a bore of generally cylindrical shape at its lower end merging into an inwardly tapering bore portion at its upper end, a sleeve within said cap member having a first portion within the cylindrical portion of the bore, and a second portion within the tapering portion of the bore, a plurality of spaced longitudinally extending ribs on the exterior of said first portion of the sleeve forming cement-retaining grooves adjacent the bore wall, cement in said grooves, said ribs and cement preventing relative rotation of said sleeve and cap one with respect to the other, a pair of cooperating shoulders on the sleeve and cap members limiting the longitudinal movement of the sleeve and cap member, and aligning the upper end of the sleeve with the upper end of the cap member, opposed bores in said sleeve, the lower bore being arranged within the cap to receive the pen nib, the upper end of the cap and the sleeve forming a flush bearing surface, said cooperating sleeve and cap shoulders being disposed adjacent and below such flush surface, clip-retaining means, threaded means within the upper bore of said sleeve for receiving and securing therein said clip-retaining means, and a clip provided with a laterally extending flat ring portion mounted on said bearing surface and clamped in place by said clip-retaining means.

5. In a fountain pen, including a barrel and a nib protruding from the lower end of said barrel, a tubular cap member having a bore of generally cylindrical shape at its lower end merging into an upwardly tapering bore portion at its upper end, a sleeve within said cap member having a first portion within the cylindrical portion of the bore, a second portion within the tapering portion of the bore, and a third sleeve portion integral with and extending above said second sleeve portion, means to prevent relative rotation of said sleeve and cap member one with respect to the other, an interior shoulder adjacent the upper end of said inwardly tapering bore portion of the cap, an exterior shoulder at the junction of the second and third sleeve portions, said exterior shoulder cooperating with said interior cap shoulder to limit the longitudinal movement of the sleeve and cap member and to align the upper end of the sleeve with the upper end of the cap member, opposed bores in said sleeve, the lower bore being arranged within the cap to receive the pen nib, the upper end of the cap and the sleeve forming a flush bearing surface, said cooperating sleeve and cap shoulders being disposed adjacent and below said flush surface, clip-retaining means, means within the upper bore of said sleeve for receiving and securing therein said clip-retaining means, and a

clip provided with a laterally extending flat ring portion mounted on said bearing surface and clamped in place by said clip-retaining means.

6. In a fountain pen, including a barrel and a nib protruding from the lower end of said barrel, a tubular cap member having a bore of generally cylindrical shape at its lower end merging into an upwardly tapering bore portion at its upper end, a sleeve within said cap member having a first portion within the cylindrical portion of the bore, a second portion within the tapering portion of the bore, and a third sleeve portion integral with and extending above said second sleeve portion, a plurality of spaced longitudinally extending ribs on the exterior of said first portion of the sleeve forming cement-retaining grooves adjacent the bore wall, cement in said grooves, said ribs and cement preventing relative rotation of said sleeve and cap one with respect to the other, an interior shoulder adjacent the upper end of said inwardly tapering bore portion of the cap, an exterior shoulder at the junction of the second and third sleeve portions, said exterior shoulder cooperating with said interior cap shoulder to limit the longitudinal movement of the sleeve and cap member and to align the upper end of the sleeve with the upper end of the cap member, opposed bores in said sleeve, the lower bore being arranged within the cap to receive the pen nib and the lower end of the sleeve being positioned within the cap to form a shoulder cooperating with the end of the pen barrel to form a seal, the upper end of the cap and the sleeve forming a flush bearing surface, said cooperating sleeve and cap shoulders being disposed adjacent and below said flush surface, clip-retaining means, means within the upper bore of said sleeve for receiving and securing therein said clip-retaining means, and a clip provided with a laterally extending flat ring portion mounted on said bearing surface and clamped in place by said clip-retaining means.

7. The fountain pen defined in claim 5 in which the longitudinally extending ribs on the exterior of the sleeve member are wedged against the inner wall of the cap member.

DAVID KAHN.

REFERENCES CITED

The following references are of record in the file of this patent:

UNITED STATES PATENTS

Number	Name	Date
55 653,818	Parker	July 17, 1900
1,538,675	Zinger	May 19, 1925
1,848,358	Kratz	Mar. 8, 1932
1,872,064	Cuthbert	Aug. 16, 1932
2,022,416	Hanle	Nov. 23, 1935
60 2,392,942	Ormsby	Jan. 15, 1946
2,404,063	Healy	July 16, 1946