

Dec. 25, 1934.

C. PFANSTIEHL

1,985,643

FOUNTAIN PEN

Filed March 16, 1934

Fig. 1

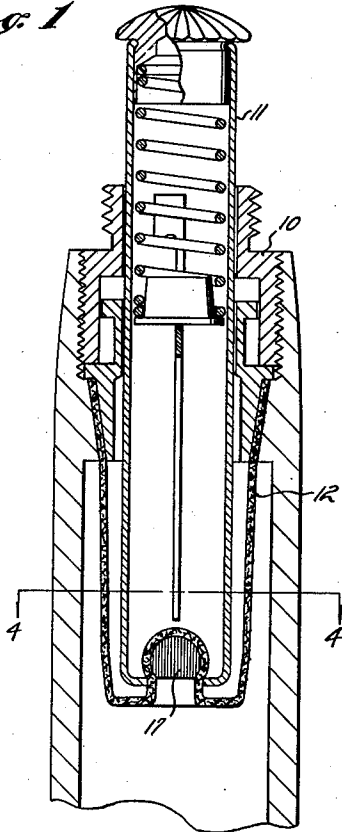

Fig. 2

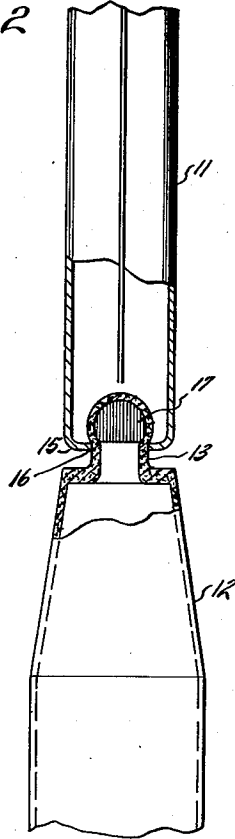

Fig. 3

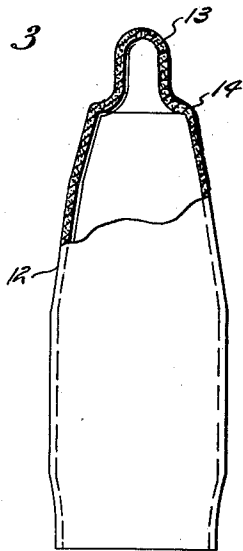
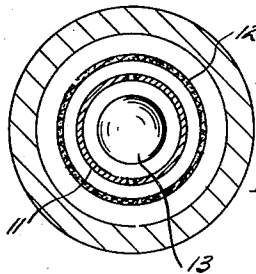

Fig. 5



Fig. 4



Carl Pfanstiehl
INVENTOR
BY *Paul W. Saff*
ATTORNEY

UNITED STATES PATENT OFFICE

1,985,643

FOUNTAIN PEN

Carl Pfanstiehl, Highland Park, Ill., assignor to
The Parker Pen Company, Janesville, Wis., a
corporation of Wisconsin

Application March 16, 1934, Serial No. 715,922

8 Claims. (Cl. 120—47)

My invention relates to fountain pens and particularly to that class generally known as pump filled in which the ink sac is eliminated and a pump mechanism is used to draw ink into the barrel. More specifically, my invention has to do with pump fill pens utilizing a rubber diaphragm as a part of the pump mechanism such as disclosed in the patent to Arthur O. Dahlberg, Number 1,904,358, issued April 18, 1933.

The pump mechanism disclosed in the drawing forming a part of this application is similar to that disclosed in the co-pending application of Ivan D. Tefft, Serial Number 636,436, filed October 6, 1932, the only change being in the shape and manner of attaching the rubber diaphragm to the end of the reciprocating metal sleeve or plunger. It is to be particularly noted that the diaphragm disclosed in the said Tefft application has a flanged nipple formed in the bottom end thereof, which flanged nipple is introduced into the lower open end of the reciprocating plunger, the flanged shoulder of the said nipple engaging on the underside of the formed shoulders adjacent the aperture in the plunger, which assembly, in conjunction with a segment or plug which is force fitted in the inside of the sleeve and pressed against the inner face of the nipple, firmly locks the lower end of the diaphragm to the lower end of the plunger.

The manufacture of a diaphragm such as shown in the Tefft and Dahlberg applications necessitates the use of a molding rubber, the composition of which is not as impervious to ink as pure latex, and as pure latex cannot be successfully molded in the form disclosed in the diaphragm of Dahlberg, I have conceived a method of affixing a slightly changed form of diaphragm to the plunger, which diaphragm may be made from pure latex.

To more fully understand my invention, reference should be had to the accompanying drawing in which:

Figure 1 discloses a sectional fragmentary view of the upper end of a fountain pen disclosing a pump in which my improved diaphragm is incorporated;

Fig. 2 is a view partially in plan and partially in section which shows the lower end of a reciprocable plunger with diaphragm attached disclosing my improved means for attaching the diaphragm to the said plunger;

Fig. 3 is a view of my improved diaphragm partially in section and partially in plan;

Fig. 4 is a view along the line 4—4 of Fig. 1; and

Fig. 5 is a plan view of a resilient segment employed in affixing the diaphragm to the end of the plunger.

In the drawing the numeral 10 is generally used to indicate the means employed for affixing the pump to one end of the pen barrel as it is not thought necessary to specifically describe the various parts in that they are exactly similar to that disclosed in the co-pending Tefft application named above.

The numeral 11 indicates a reciprocable plunger which actuates a diaphragm 12 which is adapted to roll upon itself when the plunger is reciprocated, causing a reduction in the air pressure within the barrel, in this manner drawing ink into the pen.

As stated in the preamble, the diaphragm 12 is fabricated from pure latex and is formed on a mandrel by what is commonly known as the anode process. The said diaphragm tapers from its mid-section to the closed end and the said closed end is formed in the shape of a nipple designated as 13, the restriction of the nipple 13 forming a shoulder 14, the outer diameter of that portion of the diaphragm at the shoulder being a trifle larger than the outer diameter of the lower end of the plunger 11. In the forming of the plunger 11, the lower end is turned inwardly to form a shoulder 15 and a restricted aperture 16.

The assembly of the diaphragm and plunger consists in slipping the nipple 13 through the restricted aperture 16 and then introducing a resilient plug 17, the diameter of which is larger than the diameter of the aperture 16, into the open end of the diaphragm and forcing said plug through the aperture 16 to the end of the nipple. Immediately the said resilient plug passes through the aperture 16 it expands, thus expanding the end of the nipple and securely locking the said diaphragm to the end of the plunger. The diaphragm is then rolled on itself as to encompass the lower portion of the plunger and the completed assembly is screwed into the barrel.

Having described my invention, what I claim and desire to secure by Letters Patent is:

1. In a fountain pen employing a pump fill mechanism, a vacuum pump, means for affixing and supporting said pump in a fountain pen barrel, a reciprocable plunger, a diaphragm, one end of which is fixed to the barrel and the other end of which is fixed to the barrel and the other end of the plunger, an aperture in the lower end of said plunger in which the closed end of the diaphragm is adapted to be inserted, expansible means adapted to be forced through the aperture in the lower end of the plunger into the inserted

end of the diaphragm, the resulting expansion of the expansible means and diaphragm end effecting a lock between the said plunger and diaphragm.

5 2. In a fountain pen the combination of a barrel, a plunger operable within said barrel and having an opening at its lower end, a diaphragm secured to said barrel, a portion of said diaphragm passing through and received within said plunger opening, and self-expansible means exteriorly insertable through said diaphragm portion for securing the diaphragm to said plunger for operating movement therewith.

10 3. In a fountain pen the combination of a barrel employing a pump fill mechanism, means for affixing and supporting said mechanism in said barrel, a reciprocable plunger having an opening, a diaphragm having a nipple portion formed therein, the nipple portion being insertable through said plunger opening, and means exteriorly insertable with said diaphragm nipple for automatically locking said nipple portion within said plunger to permit operation of said diaphragm by said plunger.

15 4. In a fountain pen the combination of a barrel, a reciprocable plunger operable within said barrel, and having an opening in its end within said barrel, a diaphragm secured to said barrel and having a hollow portion insertable through said plunger opening and within said plunger, an expansible plug insertable through said plunger opening and within said hollow diaphragm portion, said plug being adapted to expand the diaphragm portion within the plunger beyond the circumference of the plunger opening to effect a lock between the plunger and diaphragm.

20 5. In a fountain pen the combination of a barrel, a reciprocable plunger operable within said barrel and having an opening in its end within the barrel, a tubular, elongated diaphragm having one end closed, a reduced extension formed at the closed end of the diaphragm for insertion in said plunger opening, an expansible plug insertable into the reduced extension within said plunger, and being normally of such size that although it may be forced through said plunger opening it will expand beyond the side of said opening when inserted in said extension to prevent withdrawal

of said extension during operation of said plunger.

6. A filling mechanism for a fountain pen of the pump filled kind which comprises a flexible diaphragm of an elongated form having a closed and reduced end portion, a plunger having an aperture in one end adapted to receive said reduced diaphragm end portion, said plunger being adapted for actuation to flex said diaphragm, and means for securely locking said diaphragm to said plunger which includes an expansible element inserted within said reduced diaphragm end portion through said plunger opening and of such size that it is contracted in being so forced through said plunger opening and expands when so inserted to securely lock said diaphragm to said plunger and prevent withdrawal of said reduced diaphragm end portion from said plunger.

7. In a fountain pen, a barrel adapted to serve as an ink reservoir, and filling mechanism which includes a flexible diaphragm, means for securing the diaphragm peripherally to said barrel to close one end of said barrel and the reservoir, a member associated with said end of the barrel for flexing said diaphragm, said member being connected to said diaphragm at a central portion thereof, said member having an opening therein to receive an imperforate part of said diaphragm, and resilient means of greater size than said opening adapted to be inserted through the opening-received part of said diaphragm within said member opening and adapted to expand when so inserted to prevent withdrawal of said diaphragm from said member and to securely lock said parts together.

8. A filling mechanism for a fountain pen of the pump-fill type which comprises a reciprocable plunger, a diaphragm, said plunger having an aperture in one end thereof and said diaphragm having a reduced and closed end portion which is received within said plunger opening, and expansible means adapted to be forced within said reduced end portion of said diaphragm through said aperture in said plunger into the inserted end portion of said diaphragm, said expansible means being adapted to contract when being forced through said aperture and to expand when inserted therein to effect a lock between said plunger and diaphragm.

CARL PFANSTIEHL.