

March 26, 1929.

T. KOVÁCS  
FOUNTAIN PEN

1,706,616

Filed Sept. 15, 1927

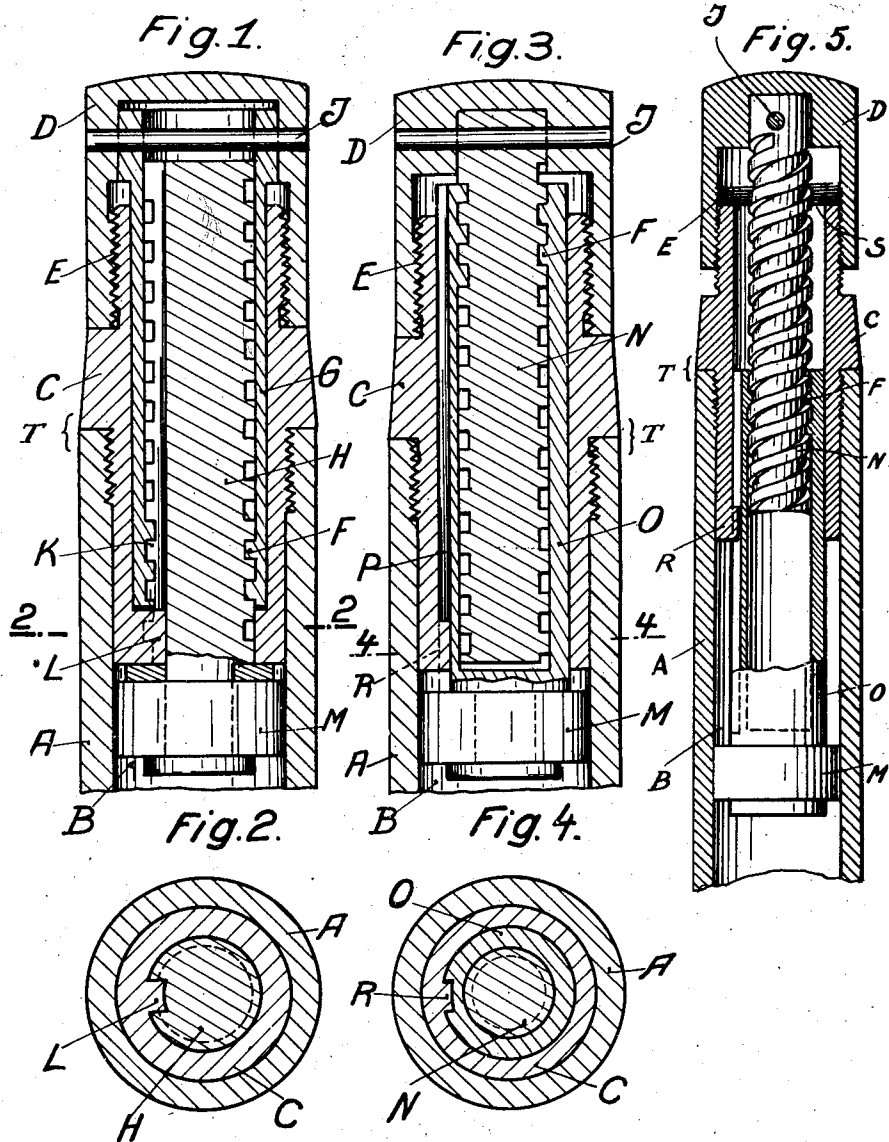

Inventor:  
Theodor Kovács  
by *Alfred...*  
His Attorney.

Patented Mar. 26, 1929.

1,706,616

# UNITED STATES PATENT OFFICE.

THEODOR KOVACS, OF BERLIN-WILMERSDORF, GERMANY.

## FOUNTAIN PEN.

Application filed September 15, 1927, Serial No. 219,578, and in Germany September 28, 1926.

My invention has reference to fountain pens having a screw-threadedly operated piston, and among other objects, I provide means for increasing the nicety of adjustment, to facilitate the manipulation and also to afford greater safety than heretofore obtainable against the spattering of the ink. In view of these and other important objects, one of the parts of the fountain pen, by the rotation of which the screw drive is operated is designed to become engaged with the stem of the fountain pen by a thread, the pitch of which is lower than the pitch of the feeding thread, the arrangement being such that the member of relatively lower pitch in that terminal position which corresponds to the inoperative position of the suction piston will provide the tightening pressure required to close the aperture in the bottom of the reservoir, through which the piston rod operates. In the preferred construction, the handle portion of the member for the operation of the feeding thread constitutes a screw cap provided with threads of low pitch and acting itself as a tightening means.

The invention will be more fully described with reference to the accompanying drawing, showing different embodiments of the principle of this invention, respectively in longitudinal and in transverse section. Fig. 1 is a longitudinal section through a fragmentary end portion of the fountain pen in which the female element of the screw drive of steeper pitch is secured to the handle portion, while the stem element of the screw drive is serving as rod of the plunger. Fig. 2 is a cross section along line 2—2 of Fig. 1. Fig. 3 is a longitudinal section through the fragmentary end portion of a similar fountain pen in which the stem portion of the screw drive of steeper pitch is screwed to the handle portion while the female element serves as a hollow piston rod. Fig. 4 is a cross section along line 4—4 of Fig. 3, and Fig. 5 is a sectional view showing the feeding screw in elevation.

In the embodiment shown in Fig. 1, A indicates generally the barrel of the ink reservoir of the pen containing cavity B. In this barrel the intermediate section C is screw-threadedly mounted which, together with the barrel constitutes the stem-section T of the device. D indicates the handle which having a low pitch-thread E is screwed onto the intermediate section and constitutes the closing cap. In the cavity of the intermediate por-

tion C, the tubular casing G having a steep-pitch interior thread F is rotatably arranged, its portion projecting from the stem-section being connected to the handle-portion D by the cross bolt or stud J. The interior thread of the casing G is in engagement with a corresponding exterior thread of a rod H which carries the piston M. The rod H is provided with a longitudinal groove K to be engaged by the lug L of the intermediate portion C. Thus, upon the operation of handle D the piston is operated by means of the steep-pitch thread, while the low pitch thread of the intermediate portion C is engaged by the handle D.

In the modification according to Figs. 3 and 4 those parts corresponding to the same parts in Figs. 1 and 2 are designated by the same reference characters. In this second embodiment the steep-pitch threaded rod N of the feeding means is connected to the handle section D, while the casing O of the screw drive constitutes the piston rod. The sleeve O is provided with a longitudinal groove P adapted for engagement with the lug R of the intermediate section C.

The operation is as follows:

The fountain pen as shown in Figs. 3 and 4 is gripped by the part C and the cap D is then secured back being turned to the left. Together with the cap D the threaded rod N is turned also to the left and having like cap D a right-handed thread and as the tubular casing O is prevented by the lug R from turning also, the tubular casing O and together therewith the piston M move forward, that is, away from cap D. The thread on the rod N being steeper than the thread E in cap D, the piston M will also move forward relative to the barrel A, until the parts occupy the position shown in Fig. 5.

If, while the pen point is immersed in the ink, the cap D is turned to the right, the piston M is moved backwards thereby, until all the parts have reached the position shown in Fig. 3, and during this movement ink is drawn in below the piston M. In this position of the parts, the cap D will tightly bear against the part C closing the space above the piston M, so that any ink which may have leaked into the space behind said piston and between the tubular casing O and the part C is prevented from escaping.

A further advantage of this construction is that the force used for tightening cap D does not put any strain on the other parts, so that

the cap can be securely tightened without any danger of the other parts being damaged. Thus, the cap D will be prevented from accidentally turning backwards and thereby causing the piston M to move, whereby ink would be spilled at the pen point of the fountain pen.

It should be understood that the arrangement heretofore described with the differentiated screw threads is generally applicable to all kinds of fountain pens the piston of which is operated by screw-drive, worms or the like.

The different embodiments herein shown and described are particularly distinguished from other fountain pens by their simple construction and easy operation. It is evident that instead of employing cooperatively engaging inner and outer threads, one of these cooperating elements of the feeding means may be replaced by a stud engageable with the thread of the cooperating other element. Furthermore, it is evident that the reservoir portion and the intermediate section instead of being secured one to another by connecting means, may be made integral forming a unit stem portion; and other changes and modifications are obviously possible within the scope and spirit of the invention.

I claim:

1. In a fountain pen in combination: a stem portion comprising a tubular reservoir, a plunger axially movable in said reservoir, a high pitch screw-drive in operative connection with said plunger, rotatable means adapted to operate said screw-drive, said means comprising a part screw-threadedly engaged with said stem portion by a thread of less pitch than the pitch of said screw-drive.

2. In a fountain pen in combination: a stem portion comprising a tubular reservoir and having an annular surface, a plunger axially movable in said reservoir, a high pitch screw-drive in operative connection with said plunger, rotatable means adapted to operate said screw-drive, said means comprising a

part screw-threadedly engaged with said stem portion by a thread of less pitch than the pitch of said screw-drive; said part having an annular surface in opposition to the annular surface of said stem portion and abutting this latter surface when the plunger is in its inoperative position.

3. In a fountain pen in combination: a stem portion comprising a tubular reservoir having an aperture, a plunger movable in said reservoir, a high pitch screw drive in operative connection with said plunger, and a member screw-threadedly mounted on said stem portion by a thread of less pitch than the thread of the screw-drive and which is in operative engagement with the rotatable element of the screw-drive, said member being adapted to serve for tightly closing the aperture in the bottom of the stem portion.

4. In a fountain pen in combination: a stem portion comprising a tubular reservoir having an aperture, a plunger movable in said reservoir, a high pitch screw-drive in operative connection with said plunger, and a member screw-threadedly mounted on the stem portion by a thread of lower pitch than the thread of the screw-drive and which is in operative engagement with the rotatable element of the screw-drive, said member being adapted to provide the tightening pressure required for the closing of the aperture in the bottom of said reservoir.

5. In a fountain pen in combination: a stem portion comprising a tubular reservoir having an aperture, a plunger movable in said reservoir, a high pitch screw drive in operative connection with said plunger, and a part screw-threadedly mounted on the stem portion by a thread of lower pitch than the thread of the screw drive, and which is connected to the rotatable part of the screw-drive, and is shaped so as to act as a closing cap for the aperture in the bottom of the stem portion.

In testimony whereof I affix my signature.

THEODOR KOVACS.