

June 6, 1961

D. H. YOUNG

2,987,044

FOUNTAIN PEN NIB MOUNTING

Filed July 18, 1955

2 Sheets-Sheet 1

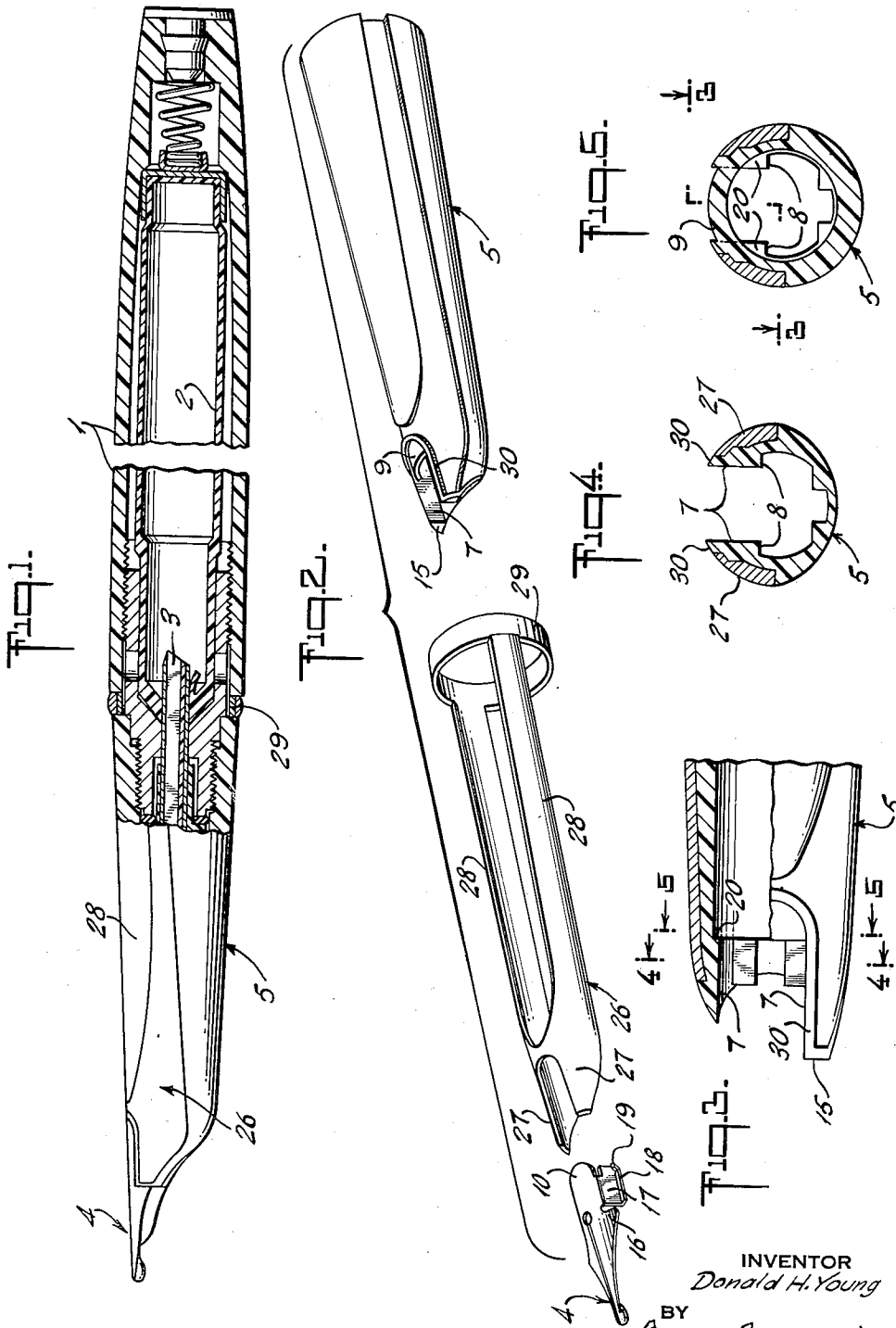

INVENTOR
Donald H. Young
BY
Ruggles Ryan Hicks
ATTORNEYS

June 6, 1961

D. H. YOUNG
FOUNTAIN PEN NIB MOUNTING

2,987,044

Filed July 18, 1955

2 Sheets-Sheet 2

Fig. 6.

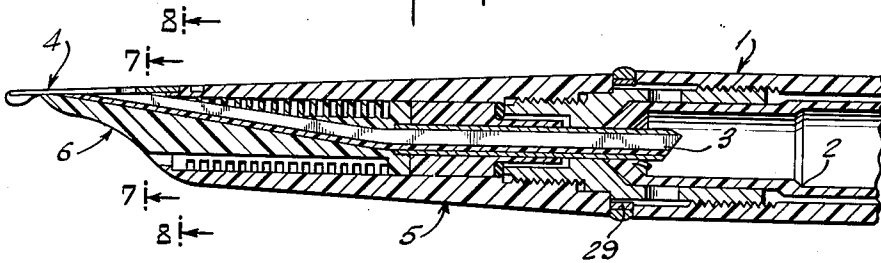

Fig. 7.

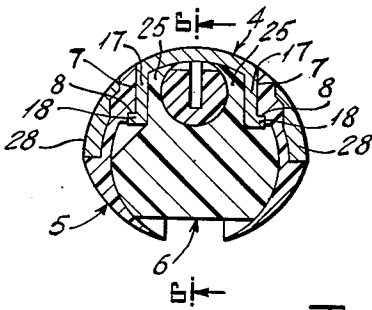

Fig. 8.

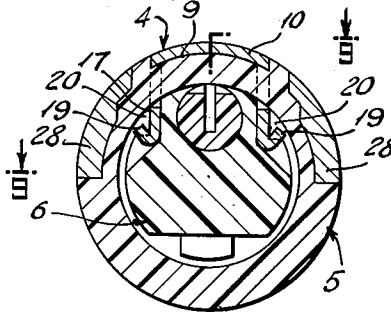

Fig. 9.

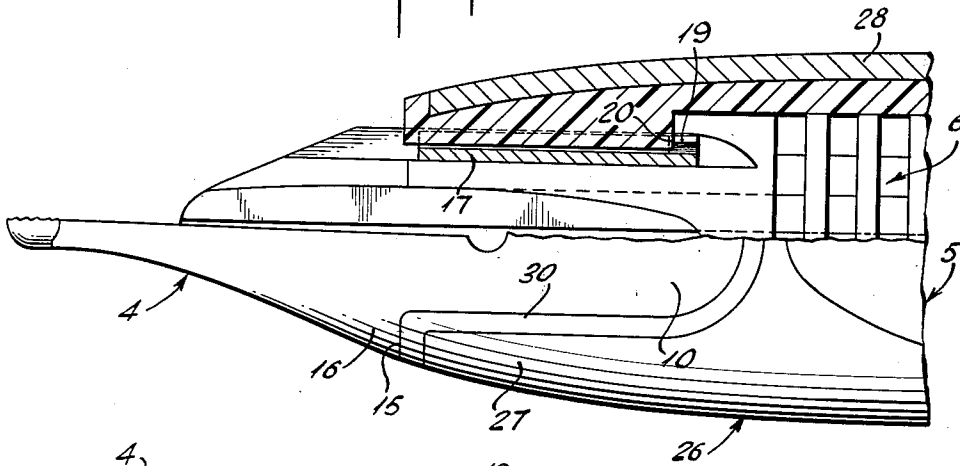
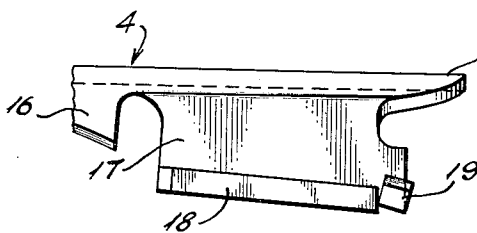

Fig. 10.



INVENTOR
Donald H. Young
BY
Burgess Ryan & Hicks
ATTORNEYS

2,987,044

FOUNTAIN PEN NIB MOUNTING

Donald H. Young, Southbury, Conn., assignor to Waterman Pen Company, Inc., New York, N.Y., a corporation of New York

Filed July 18, 1955, Ser. No. 522,496

7 Claims. (Cl. 120—51)

This invention has to do with the mounting of a nib in the forward end portion, or "section" as it is called, of a fountain pen.

The principal object is to provide a novel form of mounting which not only holds the nib securely but which also permits much (or, if desired, all) of the nib to be exposed and supported flush with the adjacent outer surface of the section so as to present an attractive, stream-lined appearance. The object is achieved without resort to the tubular type of nib with which certain pens have heretofore been equipped.

In general, the above result is achieved by utilizing a nib which, when in position, may have the appearance of a nib of standard design, including the usual U-shaped rear end, but which has depending side flange means which penetrate the section and serve, in part at least, to interlock the nib and section.

The invention will be better understood from the following description of the preferred form illustrated in the accompanying drawings of which:

FIG. 1 is a partially sectioned side view of a fountain pen incorporating the preferred form of the invention;

FIG. 2 is an exploded perspective view of the nib, a reinforcing element and the section;

FIG. 3 is an enlarged top plan view (partially sectioned on the line 3—3 of FIG. 5) of the forward end of the section, with the nib removed;

FIGS. 4 and 5 are transverse sections on the lines 4—4 and 5—5, respectively, of FIG. 3;

FIG. 6 is a vertical longitudinal section of the forward end of the pen of FIG. 1, the section being taken on the line 6—6 of FIG. 7;

FIGS 7 and 8 are transverse sections on the lines 7—7 and 8—8, respectively, of FIG. 6;

FIG. 9 is an enlarged top plan view of the forward end of the section (with the nib in position) and partially sectioned, as on the line 9—9 of FIG. 8; and

FIG. 10 is an enlarged side view of a portion of the nib.

The particular pen shown in FIG. 1 for the purposes of illustration includes a barrel 1, housing an ink cartridge 2 the forward or left-hand end of which is pierced by a tube 3 which, through a feed forming no part of the present invention, serves to conduct the ink from the cartridge to the nib 4. The nib is mounted at the forward end of the so-called section, generally designated 5.

Throughout this specification and the claims, the terms "front," "forward" etc. are used to designate that portion of an element which is nearer to or faces the nib end of the pen and the terms "rear," "rearward" etc. are used to designate the portion of an element which is remote or faces away from the nib end of the pen.

Within the section 5, which is of open-ended tubular form, is an ink storage member 6 the details of which (so far as ink storage and flow are concerned) likewise form no part of the present invention.

The forward end of the section 5 incorporates a nib-receiving cavity. In this preferred form the cavity, in plan view, is U-shaped, the forward part of the cavity being a slot providing opposed side surfaces 7 (see FIG. 4). The slot is of a width less than the diameter of the section bore so that, at the intersection of the surfaces 7 with the surface of the section bore, under-cut portions or shoulders 8 are formed. The rear end of the nib cavity

is bridged by a nib seat 9 (see FIGS. 2 and 5) which is depressed to a depth approximately equalling the thickness of the nib 4. Accordingly, when the U-shaped rear end 10 of the nib is engaged with seat 9, the outer surface of the nib will be substantially flush with the adjacent outer surface of the section (see FIG. 8). As seen in FIG. 9, the forward end of the nib projects beyond the section.

The extreme forward end of the upper part of section 5 terminates in square shoulders 15 (FIGS. 2, 3 and 9) and, when the nib is in position, its wing portions 16 (FIG. 9) substantially abut these shoulders so that, in plan view, the projecting front end of the nib appears as a stream-lined extension of the section.

As stated above, the nib is provided with depending side flange members which penetrate the section and serve to interlock the nib and section. As illustrated, the nib has depending side flanges 17 which, in this preferred form, terminate in integrally formed lateral projections 18, the side flanges engaging the section surfaces 7 and the lateral projections engaging beneath the section shoulders 8 (see FIG. 7).

The rear end portions 19 of projections 18 are slit and bent upwardly and outwardly so as to engage behind the rearwardly facing section shoulders 20, thereby locking the nib against withdrawal in a forward direction (see FIGS 8 and 9)

The forward end of the ink storage member 6 is a snug fit in the section bore (see FIG. 6) and its upper wall portions 25 engage the under side of the nib to complete its support and also engage the inner sides of the depending nib flanges, thereby holding the flanges spread and their lateral projections engaged beneath section shoulders 8.

In this preferred embodiment the nib cavity is shown reinforced by a member which serves also to ornament the pen section and without disturbing its overall stream-lined appearance. This member, generally designated 26 in FIGS 1 and 2, may be a metal piece embedded in the section so that its surface is flush with that of the section. Assuming the section to be plastic molded, the member 26 can be inserted in the mold and the section molded to it. At its forward end member 26 includes a yoke 27 and extending rearwardly are wings 28 united at their ends by a band 29. As appears in FIGS. 2 and 9, the yoke of the reinforcing member terminates short of section shoulder 15 and also is spaced from the edge of the nib cavity. In the result, the nib cavity is bordered by a rib 30, which is an integral part of the section, and the yoke embraces the rib along both sides and around its U-shaped inner end.

It will be apparent that with this arrangement the rib serves to insulate the nib from the reinforcing member and that the two may therefore be of dissimilar metals. The rib serves not only to insure against electrolytic action but also to minimize the danger of ink creeping back from the nib to the reinforcing member.

It will also be understood that the features and principles exemplified in the preferred form illustrated and described are susceptible of embodiment in numerous forms and combinations.

In the light of the foregoing the following is claimed:

1. In a fountain pen, the combination of a tubular, open-ended section, the top wall of the section at its forward end incorporating a nib slot extending through the section wall and providing opposed side surfaces, said section having a pair of forwardly axially directed end faces at the opposite sides of the open end of said slot and having a pair of laterally spaced rearwardly axially directed internal stop faces, a nib having opposite side wings adapted to abut said end faces and depending side flanges spaced to engage the said side surfaces, an ink

3

storage member in the section bore having upper wall portions adapted to engage the under side of the nib, and means providing locking projections on said flanges within the section bore in abutment with said internal stop faces.

2. In a fountain pen, the combination of a tubular, open-ended section, the top wall of the section at its forward end incorporating a nib slot extending through the section wall and providing opposed side surfaces, said side surfaces being undercut to provide downwardly facing shoulders, a nib disposed in said slot and having depending side flanges spaced to engage the said side surfaces and outwardly turned end portions adapted to fit under said shoulders, an ink storage member in the section bore and having wall portions adapted to engage the under side of the nib, the engagement of the shoulders by the said nib portions locating the nib with its outer surface substantially flush with the adjacent outer surfaces of the section, and axially abutting locking formations on said nib flanges and the interior of said section.

3. In a fountain pen, the combination of a tubular, open-ended section, the top wall of the section at its forward end incorporating a nib slot extending through the section wall and providing opposed side surfaces, said side surfaces incorporating under-cut shoulders, a nib having depending side flanges spaced to engage the said side surfaces and terminating in lateral oppositely outwardly extending projections adapted to engage beneath said shoulders, an ink storage member in the section bore and having wall portions adapted to engage the under side of the nib, the said nib flanges being of a length to locate the outer surface of the nib substantially flush with the adjacent outer surfaces of the section when the lateral projections are engaged beneath the said shoulders, and means for securing said nib on the section comprising a first set of cooperating axially abutting portions on said nib and the section adjacent said nib slot and a second set of cooperating axially abutting portions on the nib flanges and the interior of said section.

4. In a fountain pen, the combination of a tubular, open-ended section, the top wall of the section at its forward end incorporating a nib slot extending through the section wall and providing opposed side surfaces, the width of the slot being less than the diameter of the section bore, whereby under-cut shoulders are formed at the junctures of the said side surfaces with the surface of the section bore, a nib having depending side flanges spaced to engage the said side surfaces and oppositely outwardly extending lateral projections adapted to engage beneath said shoulders, an ink storage member in the section bore and having wall portions adapted to engage the under side of the nib and the inner sides of the said depending nib flanges, and means for securing said nib on the section comprising a first set of cooperating axially abutting portions on said nib and the section adjacent the nib slot and a second set of axially abutting portions on said nib flanges and the interior of said section.

5. In a fountain pen, the combination of a tubular, open-ended section, the forward end of the section in-

4

corporating a U-shaped nib-receiving cavity bordered on its sides and around its inner end by an upstanding rib, the rear end of the cavity being of nib-thickness depth, a nib located in the cavity with its outer surface substantially flush with the top of the said rib, the rear end of the nib being U-shaped and seated on the said rear end of the cavity, said nib having depending side flange means penetrating the section, and a U-shaped reinforcing yoke embracing the sides and rear end and substantially flush with the top of the said rib.

6. In a fountain pen, an open ended tubular section having at one end a nib receiving cavity that is open to said one end of the section and is provided with a shallow nib seat remote from said cavity open end and parallel side surfaces between said seat and said open end, said one section end also being provided with axially forwardly facing nib abutment shoulders at opposite sides of said cavity, an ink storage member mounted within said section, and a nib mounted on said section at said cavity so as to engage the adjacent portion of said ink storage member and having in longitudinal succession, a point, lateral side wings, depending side flanges, and a portion received on said seat, said wings abutting against said nib abutment shoulders, and said flanges extending between said cavity side surfaces and adjacent portions of said ink storage member, and means interlocking said nib flanges with said section interiorly of the latter comprising longitudinally extending undercut shoulders within said section and opposite lateral projections on said flanges extending under said shoulders and axially rearwardly facing shoulders within said section and locking projections on said nib flanges abutting said rearwardly facing section shoulders, said locking projections extending angularly with respect to said lateral projections and being located rearwardly of said lateral projections.

7. A fountain pen nib formed from a single piece of metal comprising a transversely arcuate main portion slitted at one end to form a writing point and provided with a section seating region at the other end, spaced laterally extending wings on said nib, spaced depending side flanges on said nib between said wings and said seating region, oppositely outwardly extending projections on the lower ends of said flanges, and axial nib locking means on each of said projections at the ends thereof adjacent said seating region comprising end sections of said lateral flange projections that are displaced upwardly in the direction of said seating region.

References Cited in the file of this patent

UNITED STATES PATENTS

| | | |
|-----------|----------|---------------|
| 662,357 | Grass | Nov. 20, 1900 |
| 1,442,959 | McComish | Jan. 23, 1923 |
| 1,939,753 | Wood | Dec. 13, 1933 |
| 2,390,541 | Klagges | Dec. 11, 1945 |
| 2,432,112 | Lovejoy | Dec. 9, 1947 |

FOREIGN PATENTS

| | | |
|--------|---------|---------------|
| 69,567 | Germany | June 28, 1893 |
|--------|---------|---------------|