

June 6, 1950

L. MOHOLY-NAGY

2,510,648

PEN DESK SET

Filed Dec. 22, 1945

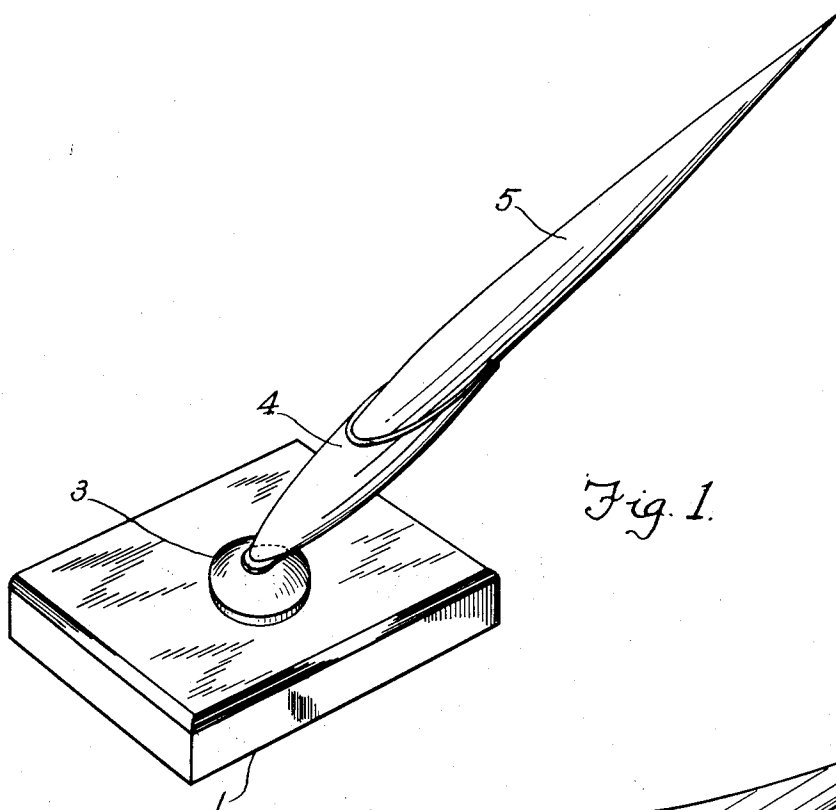

Fig. 1.

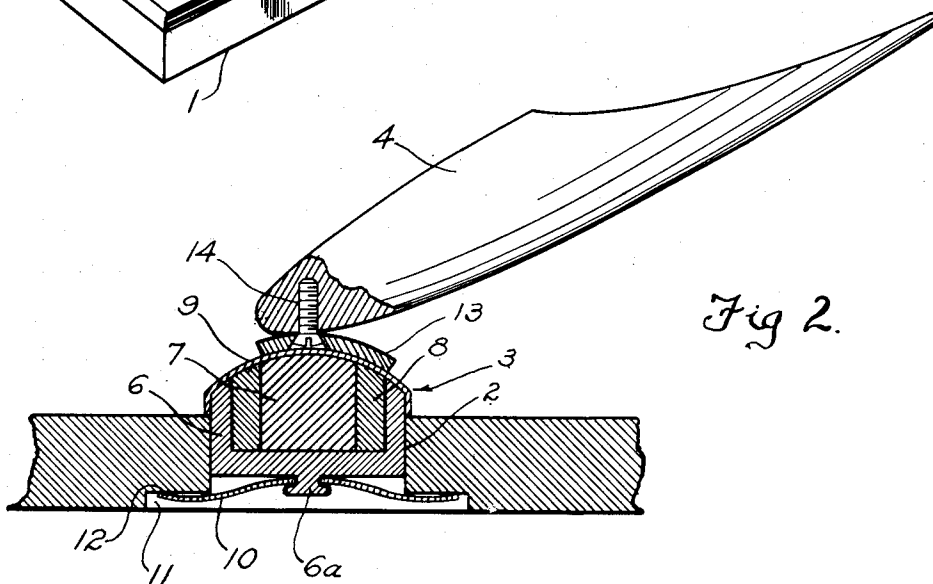

Fig. 2.

INVENTOR.
LÁSZLO MOHOLY-NAGY

BY

Fidler + Crouse
ATTORNEYS

UNITED STATES PATENT OFFICE

2,510,648

PEN DESK SET

Laszlo Moholy-Nagy, Chicago, Ill., assignor to The Parker Pen Company, Janesville, Wis., a corporation of Wisconsin

Application December 22, 1945, Serial No. 636,745

3 Claims. (Cl. 175—367)

1

This invention relates to pen desk sets and it has to do particularly with desk sets of that type wherein the pen receptacle is secured to a base by magnetic means and is adjustable angularly and rotatively to suit the preference of the user.

An object of my invention is to provide an improved set of the foregoing character which is of simple and inexpensive construction and is adapted to serve its pen supporting and positioning functions with a high degree of efficiency.

Another object is to provide a desk set wherein the pen-receiving receptacle may be readily and easily detached from its magnetic support for storage purposes.

A further object of my invention is to provide a structure which is well adapted to the effectuation of novel and artistically attractive desk set designs, and which is suited for economic manufacture in volume.

My invention is particularly characterized in that a permanent magnet structure is mounted in or on the base and is so shaped as to present a magnetized hemispherical convex surface adapted to be engaged by a complementally-shaped concave shoe of paramagnetic material attached to one end of the pen-receiving receptacle and adapted to adhere by magnetic attraction to the aforementioned magnetized convex surface.

Other objects and features of my invention will be evident from the description which follows and by reference to the drawing wherein:

Figure 1 is a perspective view of one form of desk set embodying my invention; and

Fig. 2 is an enlarged vertical sectional view of the structure shown in Fig. 1.

The assembly illustrated includes a base 1, which may be of any suitable design and of any appropriate material. Base 1 has a central opening 2 in which is secured a magnet structure 3, serving as a support for a pen receptacle 4. Receptacle 4 is adapted to receive and support a pen 5.

The magnet structure or unit 3 comprises a cup-like casing 6 made preferably of iron or other paramagnetic material. The casing 6 serves as a part of the magnetic circuit and at the same time as a receptacle in which is mounted a core consisting of a permanent bar magnet 7. The magnet 7 may be made of "Alnico" or other similar alloy and is held in concentric relation to casing 6 by an annular spacing member 8 of diamagnetic material, as for example, brass. Core or magnet 7 is so magnetized that its upper

2

and lower extremities are of opposite magnetic polarity. Thus, as will be apparent, the upper peripheral extremity of casing 6 has a magnetic polarity which is opposite that of the upper extremity of core 7.

The upper surface of the assembly comprising casing 6, core 7 and spacer 8 is spherically convex to produce an upper dome-like formation; and the upper surface of this assembly is encased within a dome-like sheet metal cap 9, the top surface of which is of complementary, spherical convex form. Cap 9 is preferably quite thin and is, preferably, made of diamagnetic material such, for example, as brass. Cap 9 is, preferably, press fitted upon the magnet unit 3 so that all parts of the unit are retained in desired assembled relation. The upper or exposed surface of cap 9 may be plated with gold or chromium.

The magnet unit 3 may be secured to base 1 in any desired manner, and I have shown an arrangement for this purpose which is convenient and economical and at the same time permits of the magnet structure being quickly detached.

Specifically, I employ a leaf spring 10 which is notched laterally at its mid-point to engage a button 6a which may form an integral part of casing 6. The bottom of the base 1 is recessed or undercut at 11 to provide an inward, annular shoulder 12 against which the arms or extremities of spring 10 bear. The spring arms are so shaped and the other parts are so relatively constructed that they engage the shoulder 12 under slight tension so as to hold the magnet structure 3 upon and attached to the base 1 with the peripheral edge of cap 9 seated on the top of the base.

The receptacle 4 is attached to base 1 by a shoe 13. Shoe 13 is formed of paramagnetic material, preferably iron or steel, and is attached to the forward or closed end of the pen receptacle by a screw 14. This shoe is spherically concaved on its under surface complementally to the spherical convexity of the top surface of cap 9 on which the shoe rests. Shoe 13 is of such size that the effective magnetic attraction causes it to adhere to the magnet structure 3 sufficiently to counteract the torque imposed by pen receptacle 4 and pen 5. At the same time the expanse of shoe 13 compared to that of the surface of cap 9 on which it rides should be small enough to permit a considerable movement in the vertical plane whereby to enable the pen receptacle to be adjusted vertically through a con-

3
siderable angle. In other words, the parts are so sized that the pen and receptacle may be moved to and held in any desired angular and rotative position. It will be evident from inspection of the drawing that the pen receptacle together with shoe 13 can be revolved in the horizontal plane while the shoe remains in contact with the magnet structure; and it will be further evident that with a shoe dimensioned as shown in Fig. 2 the pen receptacle is movable through a considerable vertical angle. Thus, the pen receptacle can be adjusted to practically any angle which the user may prefer.

For ornamental purposes, the design of the shoe, as well as the pen receptacle and base, is subject to almost infinite variation and it will be manifest that the invention affords the industrial designer very wide scope in the production of pen desk sets having good eye appeal.

One of the mechanical advantages of a pen desk set constructed in accordance with my invention is that it entails no parts which are either delicate or difficult to produce or which can get out of order as a result of wear. Another material advantage lies in the fact that the pen receptacle with the shoe attached can easily be withdrawn from the base with the pen and put away for safe keeping—the pen receptacle thereby continuing to function as a cap to prevent drying out of the pen.

I claim:

1. A permanent magnet structure adapted to support a desk set pen receptacle having a concave member of paramagnetic material; said permanent magnet structure being carried by a base and presenting a spherically convex surface conforming to and of such extent that said spherically concave surface extends over a portion only thereof for mounting said receptacle for sliding movement thereon, said magnetic structure including a cupped member of paramagnetic material, a permanently magnetized core member disposed in said cupped member and connected magnetically at one end to the bottom wall of said cupped member, a liner of diamagnetic material interposed between said core member and the side walls of said cupped member, and a cap element of diamagnetic material extending over the end faces of said cupped and core members and secured to said cupped member to retain said core member and said diamagnetic material in said cupped member, said cupped member and said core member providing two pole portions of opposite polarity terminating with their end faces in close proximity to said convex surface and positioned to act magnetically on said paramag-

4
netic material when said receptacle is in position on said base with the concave surface thereof resting on the convex surface of said cap element.

2. A permanent magnet structure adapted to support a desk set pen receptacle having a concave shoe element of paramagnetic material; said permanent magnet structure being mounted on a base and including two pole portions of opposite polarities terminating in a spherically convex surface, and a cap element of non-oxidizing diamagnetic material extending over the ends of said pole portions and providing an exposed, spherical convex surface of greater extent than the concave surface of said shoe element and shaped complementally thereto for supporting said shoe element for sliding movement on said cap element and in close proximity to the ends of said pole portions.

3. A permanent magnet structure adapted to support a desk set pen receptacle having a spherically concave element of paramagnetic material; said permanent magnet structure being carried by said base and including a cupped member of paramagnetic material, a permanently magnetized core member disposed concentrically in said cupped member and connected magnetically at one end to the bottom wall of said cupped member, and a liner of diamagnetic material interposed between said core member and the side walls of said cupped member, and a cap element of diamagnetic material extending over the end faces of said core member and said cupped member and presenting an exposed spherical surface formed complementally to the spherical surface of said paramagnetic element but of greater extent whereby said paramagnetic element is slidable over the surface of said cap element to permit rocking and rotational adjustment of said receptacle on said base.

LASZLO MOHOLY-NAGY.

REFERENCES CITED

The following references are of record in the file of this patent:

UNITED STATES PATENTS

Number	Name	Date
1,932,143	Piercy	Oct. 24, 1933
1,945,271	Hanle	Jan. 30, 1934
2,269,149	Edgar	Jan. 6, 1942
2,297,806	Smith	Oct. 6, 1942

FOREIGN PATENTS

Number	Country	Date
126,414	Switzerland	June 16, 1928