

Sept. 6, 1927.

1,641,846

J. A. FREMON ET AL

FOUNTAIN PEN RACK

Filed Jan. 16, 1925

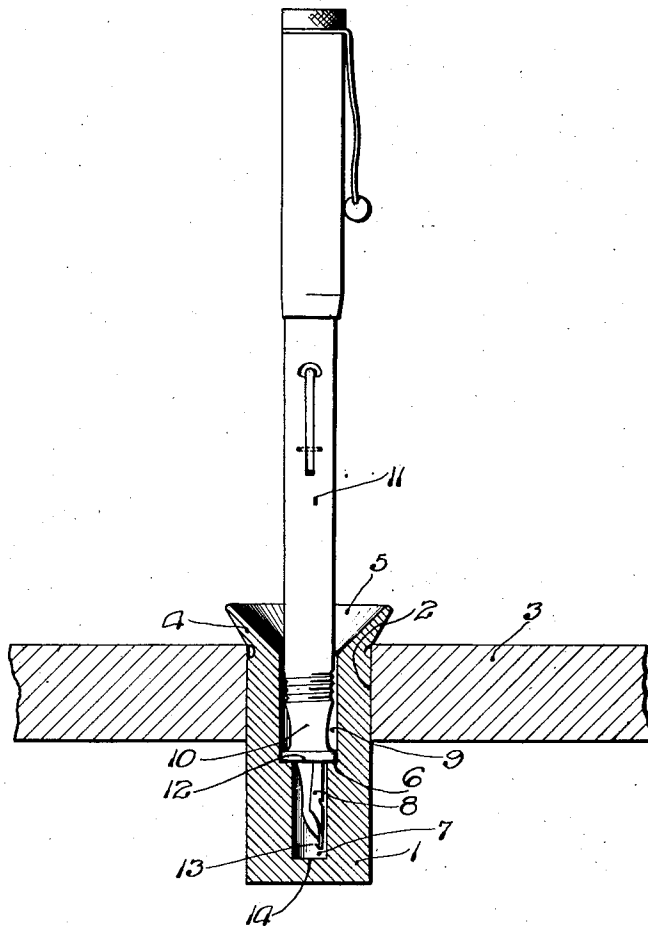

INVENTORS
Jules A. Fremon
Avery S. De Haven
BY Nissen & Crane
ATTYS.

UNITED STATES PATENT OFFICE.

JULES A. FREMON AND AVERY S. DE HAVEN, OF LEEPER, MISSOURI, ASSIGNORS TO
W. A. SHEAFFER PEN COMPANY, OF FORT MADISON, IOWA, A CORPORATION OF
DELAWARE.

FOUNTAIN-PEN RACK.

Application filed January 16, 1925. Serial No. 2,782.

Our invention relates to receptacles for holding fountain pens, and has for one of its objects the provision of a pen holding device which will retain a fountain pen in a convenient position upon a desk or table.

A further object of the invention is the provision of means which will prevent evaporation of ink from a fountain pen.

A still further object of the invention is the provision of a device for holding a fountain pen in such a position that the pen portion thereof may be retained moist.

A still further object of the invention is the provision of a receptacle for holding fountain pens with the pen portion depending downwardly and spaced apart from the walls and bottom of said receptacle.

Other objects of the invention will appear hereinafter, the novel features and combinations being set forth in the appended claim.

An embodiment of the invention is illustrated in the accompanying drawing, forming a part of this specification, and in which:

Fig. 1 is a sectional view of a pen holding receptacle and a perspective view of a fountain pen mounted therein.

Referring more particularly to the drawing, it will be seen that a hard rubber tubular member 1 is mounted in an opening 2 in a desk member 3. The receiving end 4 of the tubular member 1 is flared outwardly at the upper end 5 to form an elongated funnel-shaped mouth, and to provide an abutment to rest upon the edge of the opening 2 in the desk 3, thereby retaining the receptacle in a vertical depending position. The bell-shaped receiver 5 provides a comparatively large cylindrical opening, into which the fountain pen 11 can easily be inserted without danger of injuring the point of the pen.

The construction of the device is clearly shown in the drawing, wherein a tubular member 1 is shown fitting into the opening 2, in the desk 3. The tubular member or pen rack should be inserted in the opening 2 with the central axis thereof vertical, said opening being large enough to permit the insertion of the tubular member 1, and small enough to prevent passage of the flared end 4 therethrough. It should be understood that the tubular member 1 is not attached in any way to the desk 3, and that said

tubular member can easily be removed from its opening 2 without necessitating adjustment or the removal of any of the parts of the device.

The fountain pen rack or tubular member 1 is provided with a cylindrical chamber extending downwardly from the flared or bell-shaped mouth 3, but the lower end portion of such chamber is of reduced diameter to afford a horizontal shoulder 6. The lowermost space 7 of reduced diameter extends from the bottom of the tubular member 1 a distance slightly greater than the length of the pen 8 as shown in the figure. The shoulder 6 is at the uppermost end of the chamber section 7 where a larger adjoining chamber section 9 commences. The cylindrical section 9 is slightly larger in diameter than the section 7 and is adapted to freely receive the lowermost portion 10 of the fountain pen 11. That is to say, the body portion 10 of the fountain pen is adapted to fit closely into a cylindrical portion 9 of the pen rack.

The circular end 12 of the body of the fountain pen 11 abuts against the shoulder 6 and maintains the point 13 of the pen 8 apart from the bottom 14 of the tubular member 1, so that the pen 8 cannot possibly be injured even though the fountain pen is roughly inserted into the tubular member 1. The large flaring mouth 5 at the upper end of the pen rack provides an easily accessible entrance to the receptacle and guides the fountain pen to a position concentric with the inner chamber and affords additional protection for the pen 8 in the event that the pen is not inserted directly into the section 9.

It should be understood that the end 12 of the body of the fountain pen 8 reclines upon the shoulder 6 in such a manner as to substantially seal the cylindrical section 7, both from the cylindrical portion 9 and from the atmosphere. This seal is sufficiently air tight to confine the air in the section 7.

When a fountain pen is in place in the rack as shown in the drawings the pen is depending downwardly and hence the ink in the fountain pen flows to the point, thus keeping the point thereof continually moist. The fountain pen is of such a type that ink will not drop therefrom into the chamber 7 when supported on the rack shoulder. The pen may be withdrawn from the receptacle and used immediately without requiring any preliminary shaking or manipulation of the

fountain pen to start the ink from the pen point. The small amount of air in the sealed section 7 soon becomes sufficiently saturated with moisture to prevent the ink from drying or thickening, even though the vertical position causes the ink to flow to the open end of the fountain pen.

The pen disclosed in the drawing is of the pocket fountain pen type and is shown having a cap portion thereof positioned on the closed end of the barrel. Such fountain pens may be inserted in the device embodied in this invention with the pen portion thereof depending downwardly so as to keep the point of said pen moist. By means of the enclosed chamber 7 excess evaporation or drying of the ink is prevented with the result that the fountain pen may be removed from its rack and used without requiring preliminary manipulation to cause ink to flow to the point thereof.

It should also be understood that the device eliminates the necessity of removing the cap member when the pen is to be used and securing said cap back over the pen when the fountain pen is not in use.

Obviously those skilled in the art may make various changes in the details and arrangement of parts without departing from the spirit and scope of the invention defined by the claim hereto appended, and it is

therefore not desired to be restricted to the precise construction herein disclosed.

Having thus fully described and shown an embodiment of the invention, what is desired to be secured by Letters Patent of the United States, is:

A holder for fountain pens which are equipped at the pen writing ends with shoulders, said holder comprising a tubular member, a cylindrical chamber in the lower portion of said tubular member for receiving the writing point and exposed ink feeding means of said fountain pen, a second cylindrical chamber in the upper part of said tubular member, a shoulder in said tubular member at the junction of said upper and said lower chambers, said shoulder serving as a supporting means for said shoulder on said fountain pen whereby the weight of said pen on said shoulder serves to substantially seal said lower chamber from the atmosphere to prevent ink from drying on said writing point and said ink feeding means, said upper chamber serving to align said fountain pen with said chamber when said pen is inserted in said tubular member.

In testimony whereof we have signed our names to this specification on this 9th day of January, A. D. 1925.

JULES A. FREMON.
AVERY S. DE HAVEN.