

May 2, 1950

K. S. PARKER

2,506,035

WRITING INSTRUMENT

Filed March 22, 1945

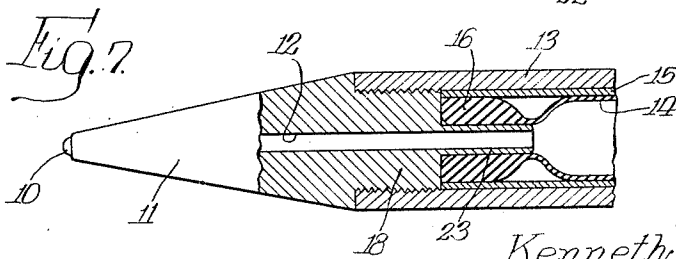
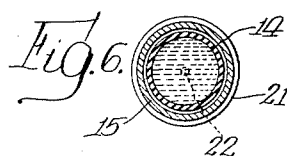
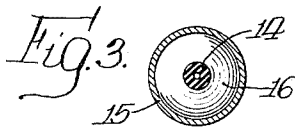
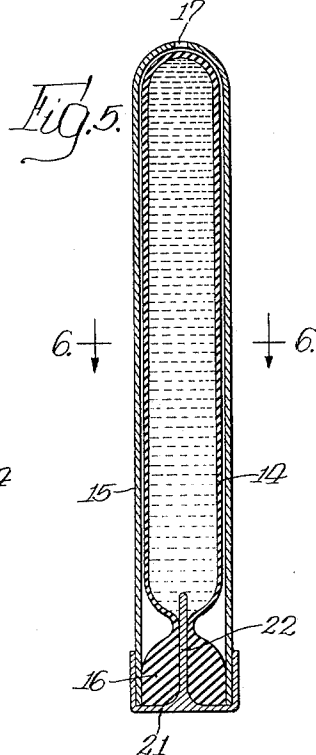
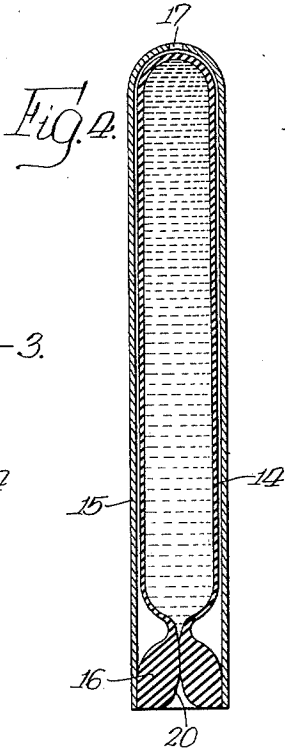
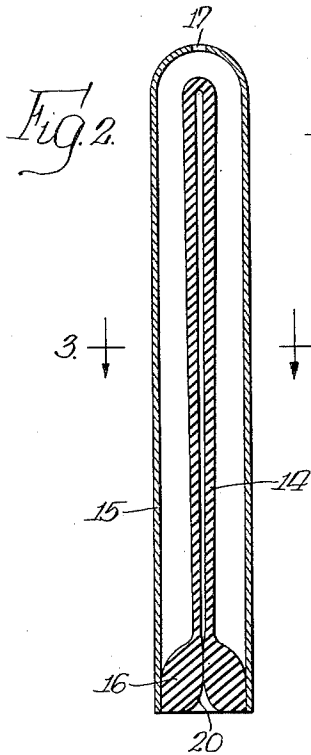
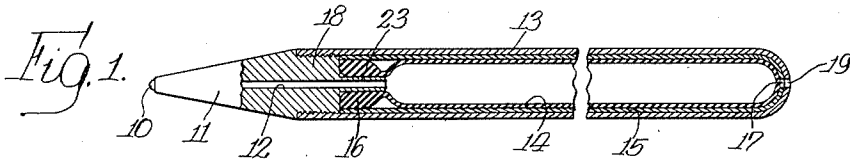

INVENTOR.
Kenneth S. Parker,
BY
Davis, Lindsey, Smith & Shorts
Attys.

UNITED STATES PATENT OFFICE

2,506,035

WRITING INSTRUMENT

Kenneth S. Parker, Janesville, Wis., assignor to
The Parker Pen Company, Janesville, Wis., a
corporation of Wisconsin

Application March 22, 1945, Serial No. 584,054

10 Claims. (Cl. 120—42.4)

1

The invention relates generally to writing instruments utilizing ink and more particularly to a writing instrument of the ball-point type.

The general object of the invention is to provide a novel ball-point writing instrument having an ink container of a resilient self-collapsible construction and adapted to feed ink therefrom to the ball point under a slight pressure by virtue of the resilient collapsing effort exerted by the container on the ink contained therein.

Another object is to provide a novel ball-point writing instrument having an ink containing sac of resilient material formed so that it tends to assume a collapsed state, the sac being adapted to be distended by the ink therein and by its resilience to force the ink from the sac to the ball point.

A further object is to provide a refill for a writing instrument of the foregoing character, the refill being adapted to be inserted into the barrel of the writing instrument and comprising a self-collapsing ink sac enclosed within the barrel and in communication with the ball point to feed ink thereto.

Still another object is to provide a refill for a writing instrument of the foregoing character, which is in the form of a cartridge comprising a self-collapsing sac for the ink, enclosed within a casing, the cartridge being readily insertible in the barrel of the writing instrument and secured therein in a manner to effect the feeding of ink to the ball point by the collapsing of the sac.

A still further object is to provide an ink cartridge comprising a sac made of resilient material and provided at one end with a discharge orifice which tends to remain closed by the resilient character of the material to retain the ink therein.

Another object is to provide an ink cartridge comprising a rigid casing enclosing a sac made of resilient material and provided with an orifice, and a removable cap for the casing providing a closure for the orifice of the sac to prevent ink from being discharged therefrom during handling.

Other objects and advantages will become apparent from the following description, taken in connection with the accompanying drawings, in which:

Figure 1 is a longitudinal sectional view of one form of ball-point writing instrument embodying the features of the invention.

Fig. 2 is a longitudinal sectional view, on an enlarged scale, of an ink cartridge adapted to be

2

used in the writing instrument shown in Fig. 1 and showing the cartridge empty.

Fig. 3 is a transverse sectional view taken on the line 3—3 of Fig. 2.

Fig. 4 is a view similar to Fig. 2, but showing the cartridge filled with ink.

Fig. 5 is a view similar to Fig. 4 except illustrating a closure cap applied to the front end of the cartridge.

Fig. 6 is a transverse sectional view taken on the line 6—6 of Fig. 4.

Fig. 7 is an enlarged longitudinal sectional view of the front end of the writing instrument shown in Fig. 1.

In an instrument of the type shown, the writing element, adapted to contact the writing surface, is a small ball 10 which is caused to rotate by such contact and which carries a film of ink on its surface adapted to adhere to the writing surface as the ball 10 rolls thereon. The ball is mounted in a socket in the tip portion 11 of the writing instrument and ink is supplied to the portion of the ball lying within the socket by means of a suitable ink feed passage 12. The ink feed passage 12 communicates with a reservoir located within a barrel or casing 13 which is secured to the tip 11 as by being threaded on a reduced shank 18 of the tip. Writing instruments of this character are adapted to utilize an ink which is relatively thick and viscous.

The ball 10 is so mounted in its socket in the tip 11 that no leakage around the ball occurs, and ink may be withdrawn from the instrument solely in the form of a film on the surface of the ball carried out of the tip by the rotation of the ball. In the present instance, the invention is not limited to any particular form of socket for the ball nor for any particular form of feed passage.

To effect a uniform supply of ink to the ball, the ink may be fed thereto under slight pressure. To this end the reservoir is in the form of a sac 14 of circular form in communication with the feed passage 12. The sac is made of a resilient material such as rubber or the like, and is formed so as to be self-collapsing. Thus, the resilience of the material when ink is in the sac places the ink within the sac under a slight pressure, and the supply of ink therein, which tends to hold the sac in its distended form, is forced through the passage 12 to the ball 10.

In its preferred form, the sac 14 constitutes the ink containing element of an ink cartridge or refill. The cartridge preferably comprises, in addition to the sac 14, a rigid casing 15 of generally tubular form surrounding the sac 14 to

3

protect it in handling. In order to retain the sac 14 within the tubular casing 15, the front or open end of the sac is enlarged as at 16 to fit snugly within and cling to the inner surface of the casing 15 and, if desired, the enlarged portion 16 may be cemented or otherwise secured to the casing. Rearwardly of the enlarged front end 16, the sac is adapted to be distended to substantially fill the interior of the casing when the sac is filled with ink, as shown in Figs. 4 and 5. In order that air within the casing externally of the sac may be discharged to prevent building up excessive pressure within the casing during filling, the latter is provided with a vent opening 17 at its rear end. Thus, the interior of the casing is maintained at atmospheric pressure.

If desired, the casing 15 may be formed without any vent opening. In such construction, the distention of the sac 14 when ink is inserted therein, in filling, compresses the air which is in the casing 15 surrounding the sac 14. The air thus compressed in the casing 15 aids in maintaining a pressure on the ink in the sac 14 and in collapsing the sac 14 behind the ink as ink is withdrawn in writing, to thereby maintain a continuous column of ink from the sac 14 to the ball 10.

If desired, the front end of the sac may be frictionally fitted into the front end of the casing 15 so that air may escape past the enlarged and thickened portion 16. When so distended, ink within the sac is under a slight pressure due to the resilience of the material of which the sac is formed, and such resilience tends to force ink from the sac through an orifice 20 in the enlarged portion 16 when the cartridge is connected with the passage 12. In order to cause the rear or closed end of the sac to be emptied first, the sac may have a thickness gradually increasing toward its rear end, as is apparent in Fig. 2, so that the rear end will tend to contract first and thus force the ink forwardly in the sac toward the orifice 20. During discharge of ink, the vent 17 permits free flow of air into the casing 15 so that there will be no tendency to form a vacuum therein and thus reduce the effectiveness of the resiliency of the sac, the barrel 13, of course, having a similar vent 19.

The enlarged front end 16 of the sac is so formed that it tends to firmly close the orifice and thus prevent ink leaking from the sac during handling of the cartridge. However, to insure against any such leakage, the casing 14 may be provided with a cap 21 fitting over the end of the casing 15 and provided with a central stem 22 adapted to extend into the orifice 20 and maintain it slightly distended. Thus, the resilience of the enlarged front end 16 causes the material thereof to hug tightly about the stem 22 and prevent any leakage of ink from the cartridge during handling of it from the time of manufacture to the time of use.

When the user desires to insert a cartridge of this character in his writing instrument, he separates the barrel 13 from the tip 11. The old cartridge within the barrel may then be removed and a new one inserted, the cap 21 having been removed from the new cartridge before such insertion. During the period after this cap is removed and before the cartridge is secured in place in the writing instrument, no leakage through the orifice can occur since the resilience of the enlarged portion 16 causes the orifice to be closed. After the cartridge has been inserted in the barrel 13, the writing tip 11 is screwed into the barrel and a tubular extension 23 on the

4

writing tip 11 is forced into the orifice 20 to place the feed passage 12 in direct communication with the interior of the sac. Thus, ink will be fed from the sac by the tendency thereof to collapse, so that the ink is supplied to the ball 10 through the feed passage 12 under a slight pressure.

This application is a continuation-in-part of my application Serial No. 527,570, filed March 22, 1944, for Ink cartridge, now abandoned.

I claim:

1. An ink package comprising a self-collapsing resilient ink containing sac having a discharge orifice, the walls of said sac increasing in thickness as the distance from said orifice increases for collapsing said walls progressively in a direction toward said orifice.

2. An ink package comprising a self-collapsing resilient ink containing sac provided with an orifice defining portion which is self-closing due to the contractile action of the resilient material surrounding the orifice.

3. An ink cartridge comprising a rigid tubular casing open at one end, and a self-contracting ink containing sac positioned in said casing and having a self-closing orifice at said open end of said casing.

4. In a writing instrument having a ball type writing element, a rigid casing, a flexible, resilient and self-collapsible ink containing sac within said casing and having a discharge orifice in one end thereof, and means including an ink feed member having an ink flow duct therein connecting said discharge orifice of said sac with said writing element, the resilience of said sac constantly exerting a collapsing action on the sac creating a pressure tending to discharge ink through said orifice and connecting means to the writing element, said sac being self-pressuring substantially throughout its entire collapsing action.

5. In a writing instrument, a rigid casing, a ball type writing element, a supporting tip for said writing element and having an ink passage leading to said writing element, and means for constantly exerting a positive pressure on a body of relatively thick, viscous ink in said casing tending to urge said ink from said casing toward said writing element, said means including a self-pressuring, resilient and flexible wall member having a first surface in contact with the ink and a vent passage in said casing for maintaining atmospheric pressure against a second surface of said wall member.

6. An ink package comprising a rigid casing for containing a supply of relatively thick, viscous ink, and a self-pressuring resilient, flexible wall member in said casing in contact with and conforming to the ink and distorted thereby, the resiliency of said wall member serving to cause it to constantly exert a pressure on said ink which tends to discharge it from said package.

7. In a ball-pointed pen employing viscous inks comprising a writing ball, a socket for said ball, and an ink reservoir connected thereto, said reservoir comprising a sac composed of resilient, flexible material, the wall of said sac being normally collapsed but expanded when ink is forced into said sac, the resiliency of said wall, when the wall is thus expanded, automatically causing said wall to exert a pressure on said ink throughout substantially the entire collapsing action of the wall tending to force said ink toward said writing ball.

8. An ink cartridge adapted to serve as a reservoir for containing viscous ink for a pen having

5

a writing point, and ink feed means leading thereto for connecting the writing point with the ink reservoir, said cartridge comprising a rigid elongate casing, means maintaining the ink constantly under at least atmospheric pressure including a flexible sac member mounted in said casing and having an open end adapted for operative connection with the ink feed means, said sac member having an imperforate self-collapsing wall which shuts off the ink therein from the atmosphere and which is constantly engaged with the ink by its self-collapsing action to avoid the formation of a sub-atmospheric pressure within the sac member behind the ink therein and constantly insure a continuous column of ink from the rear or closed end of said sac member to the ink feed means.

9. In a writing instrument, a rigid casing, a writing element, means for supporting said writing element and providing an ink feed passage leading to said writing element, and means including an imperforate flexible and resilient wall member in said casing for sealing a body of ink against contact with air, said wall member being distorted by the ink and by reason of its resilience and flexibility conforming to said body of ink and constantly exerting a pressure in excess of atmospheric pressure on said body of ink to constantly maintain a continuous column of ink from said casing to said writing element.

10. In a ball point writing instrument, a rigid casing and a resilient, self-pressuring and self-

6

collapsible sac within said casing for holding a supply of viscous ink with the sac distended by the ink, the collapsing resilience of said sac being such as to cause said sac to apply at least atmospheric pressure on the ink substantially throughout its entire collapsing action and tending to discharge ink therefrom to the ball point, said casing being vented to maintain the space within the casing and outside of the sac at atmospheric pressure.

KENNETH S. PARKER.

REFERENCES CITED

The following references are of record in the file of this patent:

UNITED STATES PATENTS

Number	Name	Date
659,989	Salisbury	Oct. 16, 1900
1,472,576	Averill	Oct. 30, 1923
1,808,377	Reichenbach	June 2, 1931
1,808,489	Bassi	June 2, 1931
2,026,657	Sherman	Jan. 7, 1936
2,053,892	Beck	Sept. 8, 1936
2,061,059	Carlson	Nov. 17, 1936
2,228,540	Sturm	Jan. 14, 1941
2,444,003	Chesler	June 22, 1948
2,444,004	Chesler	June 22, 1948

OTHER REFERENCES

Ser. No. 470,091, Leeuwin (A.P.C.), published July 13, 1943.