

Feb. 17, 1953

D. CHAPMAN

2,628,431

FOUNTAIN PEN CLEANING DEVICE

Filed Sept. 27, 1949

3 Sheets-Sheet 1

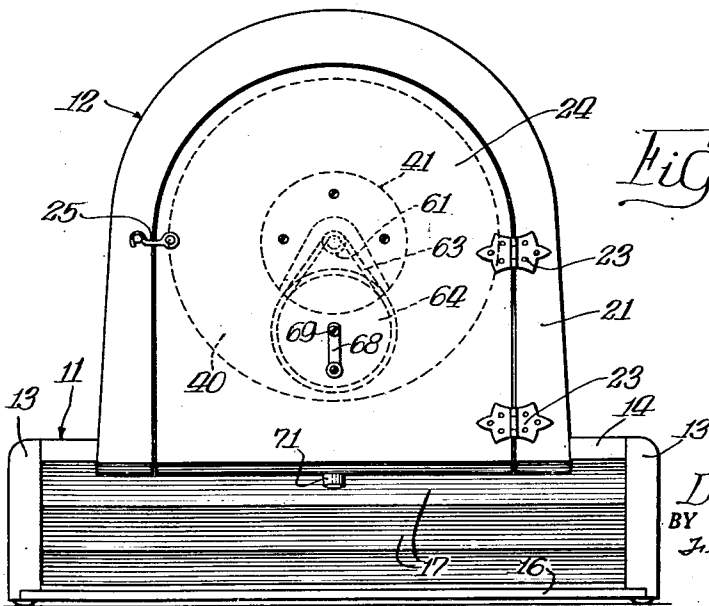
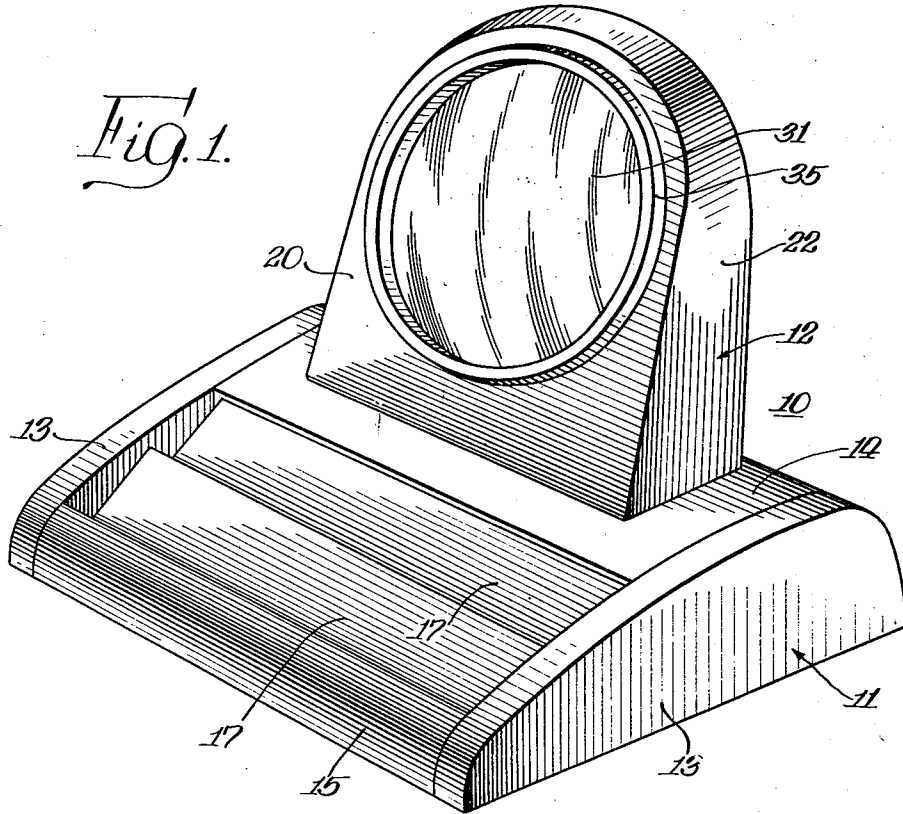

INVENTOR.
Dave Chapman
BY
Fiedler, Coover & Beardsley
Attys.

Feb. 17, 1953

D. CHAPMAN

2,628,431

FOUNTAIN PEN CLEANING DEVICE

Filed Sept. 27, 1949

3 Sheets-Sheet 2

Fig. 4.

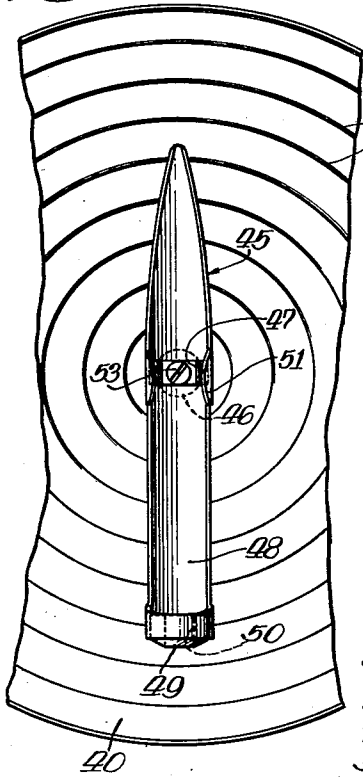
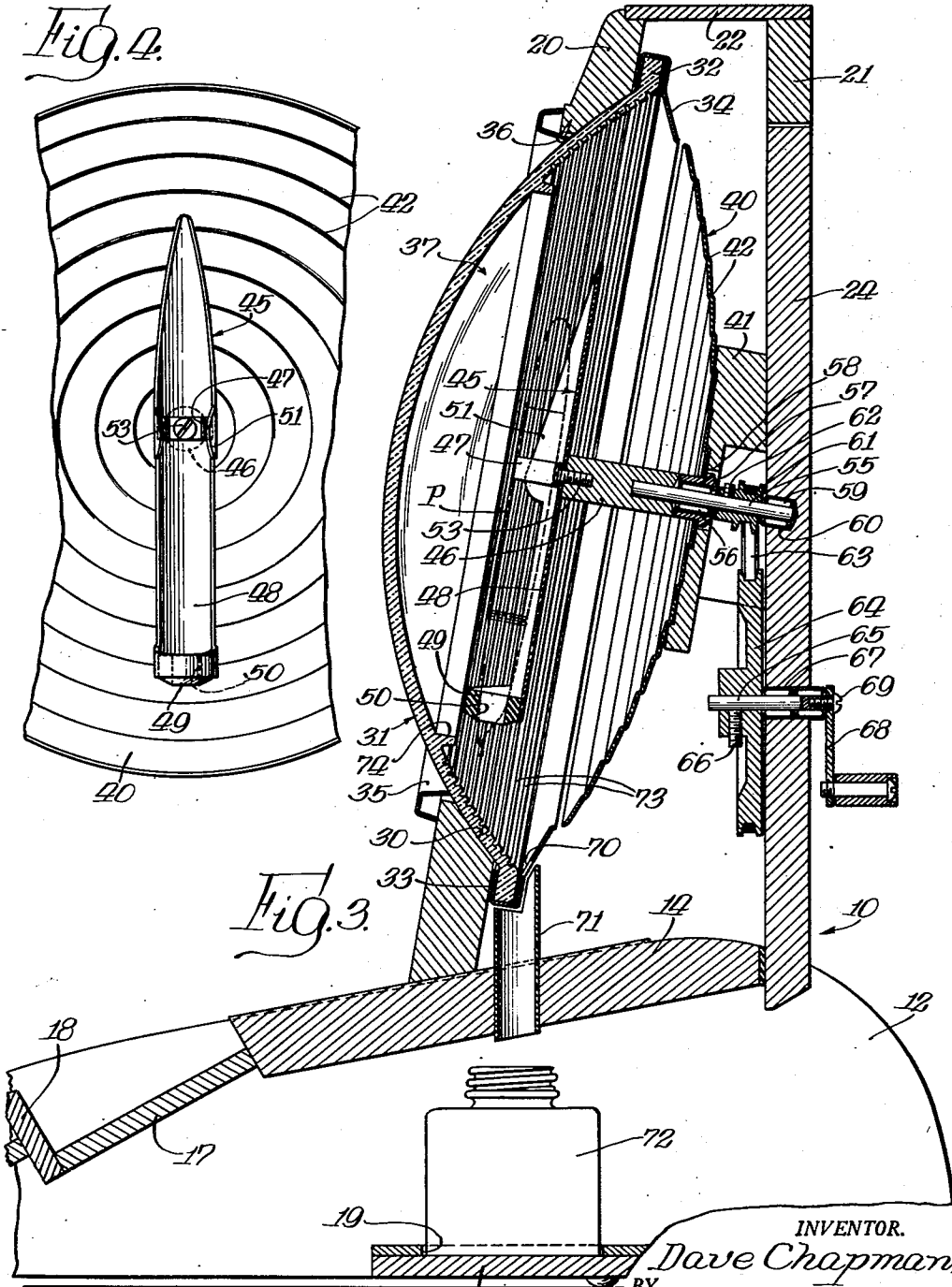

Fig. 3.



INVENTOR.
Dave Chapman
BY
Fidler, Cross & Bunsley
Attys.

Feb. 17, 1953

D. CHAPMAN

2,628,431

FOUNTAIN PEN CLEANING DEVICE

Filed Sept. 27, 1949

3 Sheets-Sheet 3

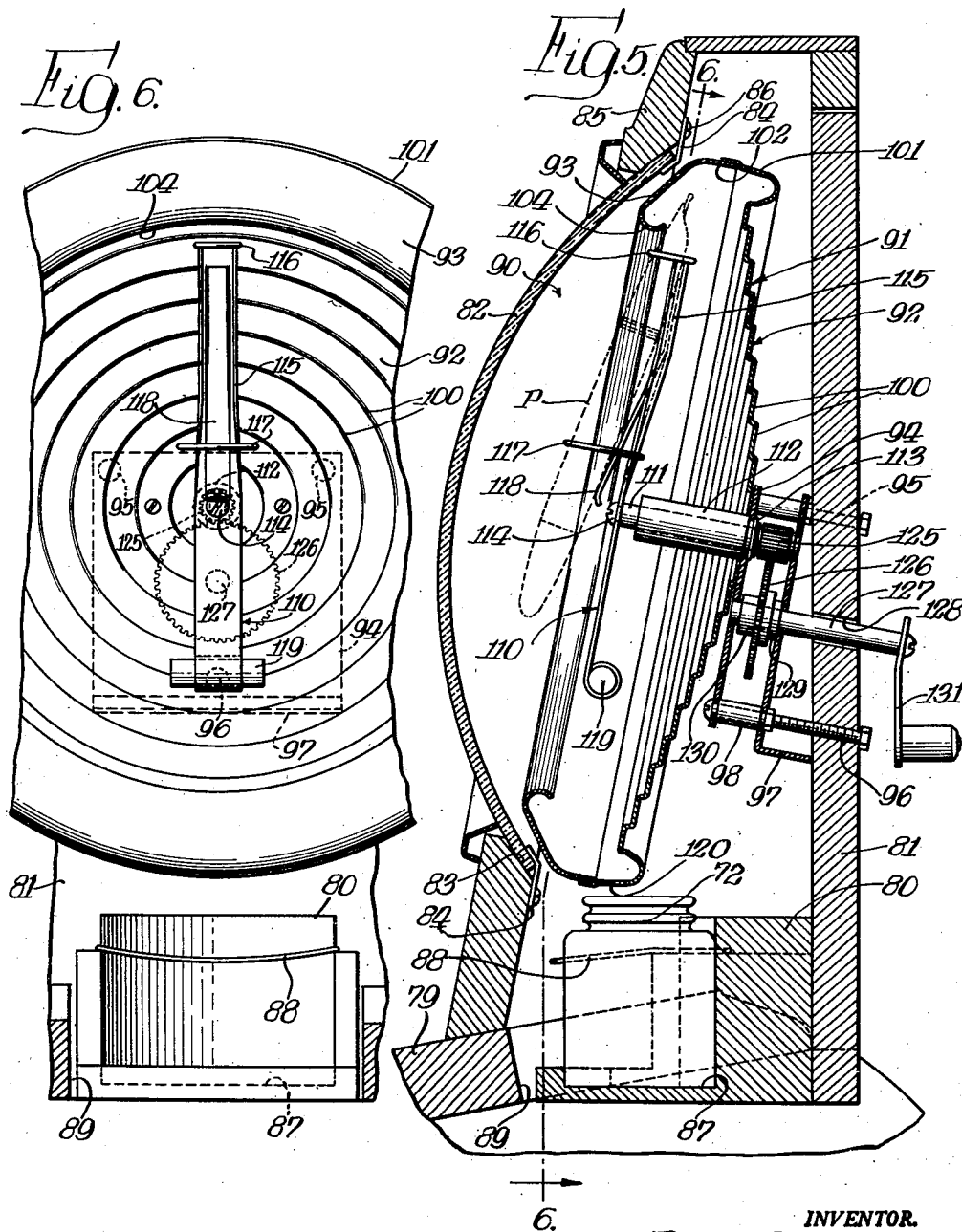

INVENTOR.
Dave Chapman,
BY
Hidler, Cronner & Bursley
Attys.

UNITED STATES PATENT OFFICE

2,628,431

FOUNTAIN PEN CLEANING DEVICE

Dave Chapman, Chicago, Ill., assignor to The Parker Pen Company, Janesville, Wis., a corporation of Wisconsin

Application September 27, 1949, Serial No. 118,100

13 Claims. (Cl. 34—58)

1

This invention relates to fountain pen cleaning devices and has to do particularly with a device for centrifugally expelling ink or other liquid from a fountain pen. While the device is adapted for use with substantially all types of fountain pens, it is especially useful in connection with fountain pens of the type having an overflow ink collector wherein ink is held by capillary action.

It is desirable to be able to remove substantially all of the ink from a fountain pen when cleaning it or when changing from one type or color of ink to another. It is almost impossible to do so by operating the filling mechanism of a fountain pen of the type having an overflow collector of the capillary type. Moreover, when a washing liquid such as water or other solvent is employed to flush the ink from the pen, such liquid is itself retained in the collector. It has been found that substantially all of the ink or other liquid which may be in a fountain pen may be expelled by the application of considerable force on the ink or other liquid in the pen such as the centrifugal force resulting from rotating the pen with the point disposed radially outwardly of the axis of rotation.

An object of the invention is to provide a simple and effective device for centrifugally expelling ink or other liquid from a fountain pen.

Another object of the invention is to provide a device of the foregoing character wherein the cleaning operation may be visually observed during the cleaning operation.

Another object is to provide a device which is attractive and which may be employed as an attention-attracting display, as well as serving the utilitarian purpose of cleaning a fountain pen.

Another object is to provide a pen-cleaning device operating on the centrifugal principle and having effective means for confining and collecting the ink or other liquid expelled from the pen and preventing such ink or liquid from being thrown against the operator or observer, or adjacent objects.

Still another object is to provide a cleaning device wherein the fountain pen may be quickly and easily inserted for the cleaning operation.

A further object of the invention is to provide a centrifugal cleaning device having simple driving means for manually rotating a fountain pen at sufficient speed to centrifugally eject the ink or cleaning liquid therefrom.

A further object of the invention is to provide a device of the character described adapted for the display of other merchandise such as ink for fountain pens.

Still another object of the invention is to pro-

2

vide a fountain pen cleaning device in the form of a display device wherein the cleaning operation may be observed as the device is mounted on a counter and the cleaning operation performed by an operator behind the counter.

Another object is to provide a completely equipped pen cleaning station at which is located both a pen rotating mechanism, which is attractively housed, and also the various pen cleaning and servicing supplies, such as cleaning liquid, wiping chamois and bottles of ink, which are readily accessible to the operator but concealed from the observer.

Other objects and advantages will appear from the following description and the appended drawings, in which:

Figure 1 is a perspective view illustrating the device of my invention;

Fig. 2 is a rear elevational view of the device of Fig. 1;

Fig. 3 is an enlarged, fragmentary, vertical sectional view of the device of Fig. 1;

Fig. 4 is a fragmentary, front elevational view of the pen-holding means of the device of Fig. 1 and a portion of the associated casing;

Fig. 5 is a fragmentary, vertical sectional view, partly in elevation, illustrating another embodiment of my device; and

Fig. 6 is a fragmentary, sectional view taken along line 5—6 of Fig. 5.

Referring now particularly to Figs. 1 to 3 of the drawings, the cleaning device comprises a cabinet 10 for enclosing the mechanism for whirling the pen, which cabinet preferably is formed of plastic or wood and so constructed as to serve also as a display stand for merchandise, as for example, bottles of ink. The cabinet 10 is formed with a lower or base portion 11 and an upper portion 12 upstanding from the base portion and adapted to house the pen rotating or "whirling" mechanism hereinafter described more in detail. The base portion 11 includes side members 13 connected by a top member 14, a front rail 15 and a floor member 16 (Fig. 3). Extending between the side members 13 are a plurality of inclined shelf members 17 and an inclined partition 18 (Fig. 3) providing racks for displaying merchandise, such racks in the present illustrative embodiment being particularly adapted for supporting bottles of ink.

The rear of the base 11 is open (Figs. 2 and 3) for permitting access to the interior so that the user can place bottles of ink, cleaning fluid, pieces of chamois skin for wiping pens, and the like on the floor member 16, as will hereinafter appear, the latter being provided with suitably

3

shaped and arranged sockets, one of which 19 is shown (Fig. 3).

The upstanding cabinet portion 12 preferably is formed by an upstanding, inclined front wall 20, a generally vertical rear wall 21, and a combined side and top wall 22 extending between the front and rear walls 20 and 21 respectively. Swingably mounted on the rear wall 21 as by hinges 23 is a door 24 adapted to form with the rear wall a closure for the rear of the upper portion of the cabinet, which door is adapted to be held in closed position by a suitable latch 25. The upper cabinet portion 12 is suitably secured on the base portion 11 as by gluing, and the top member 14 of the base portion 11 thus serves as a bottom closure for the upper cabinet portion 12.

The inclined front wall member 20 is formed with a large circular opening 30 for the purpose of permitting the cleaning operation to be observed, as will be described hereinafter. The mechanism for whirling the pen is arranged to support the pen in a generally upright position and the window is so arranged that when the display is located on a counter of customary height, the pen is in the normal line of vision of an observer standing before the counter and may be viewed conveniently. The opening 30 is closed by a dome-shaped window member 31 formed of transparent material, such as glass or a suitable plastic, molded to the desired shape. It may be explained at this point that all portions of the device which are normally subject to contact with the ink or cleaning liquids are formed of materials which are inert to the ink or other liquids.

The window member 31 is secured in position closing the opening 30, with the principal portion of the window member 31 projecting forwardly beyond the front wall 20. To this end the opening 30 preferably is formed complementally to the adjacent portion of the window member 31 and the latter is provided with a flat rim 32. In order to catch and collect the ink or other liquid which is expelled from a pen being whirled, an annular trough is provided within the upstanding cabinet section in a position radially outwardly of the path of the writing end of the pen. The trough has an open front side to permit the pen to be seen but is so shaped that all of the ink which is expelled from the trough without being thrown from or spattering from the trough. The trough forms the peripheral portion of a casing hereinafter described for defining a cleaning chamber 37 containing the pen holder and a portion of its supporting shaft.

The aforesaid trough may be formed in various ways and in the embodiment of my invention illustrated in Figs. 1 to 4 it is formed by an annular portion 38 of the window member 31 and by a ring 33 having the general shape of a portion of a cone disposed opposite the portion 38. In lieu of providing the separate metal ring 33, the window member may be formed with an integral, inwardly extending peripheral flange (not shown) generally similar in shape to the ring 33 and adapted to form with the adjacent portion of the window a trough generally similar to the trough just described. Where a window member having an integral, skirt-like flange is employed, the window member preferably is secured directly to the wall, as by cement.

The window member 31 is secured in position preferably by the annular ring 33, which preferably is formed of metal, and is spun or peened

4

around the rim 32 and which ring 33 itself is secured to the front wall 20. The ring 33 preferably has a channel shaped rim 34 which is secured to the front wall 20 by cementing the forward flange of the channel to the rear face of the front wall 20. However, if desired the rim 34 instead of being channel-shaped may be generally Z-shaped in cross-section with an outwardly extending flange (not shown) adapted to be secured to the front wall 20 by screws, or the channel may be L-shaped and the window member secured directly to the wall 20 as by cement. An annular gasket or gaskets (not shown) of rubber or cork may be interposed between the rim 32 and the rim 34 or between the rim 34 and the front wall 20, or both, in order to prevent vibration of the window member 31. A bezel ring 35 preferably formed of metal is suitably secured in the opening 30, as by tacks 36, for decorative purposes and for preventing dust from lodging in the crevice formed between the window member 31 and the opening 30.

The aforementioned casing which defines the cleaning chamber 37 is formed in part by the window member 31 and ring 33 and is completed by a dome-shaped rear closure or partition member 40, preferably formed of thin metal and suitably secured as by cement to a mounting block 41 carried by the door 24. The rear closure member 40 is of such dimensions and arrangement that its forward peripheral edge is disposed close to the inner peripheral edge of the ring 33 so as to provide a substantially closed casing with the ring 33 and window member 31. The member 40 preferably is formed with concentric circular steps or corrugations 42 which serve both to stiffen the member and to provide an attractive ornamental appearance. Inasmuch as the member 40 is mounted on the swingable door 24, access to the interior of the casing 37 may be had by swinging the door 24 to open position.

Mechanism is provided for supporting within the cleaning chamber 37 a fountain pen to be cleaned and for rotating the fountain pen about an axis transversely to the longitudinal axis of the pen and inwardly of the writing end of the pen so that ink or any other liquid which is in the pen is centrifugally expelled therefrom. To this end a pen holder or support 45 is rotatably mounted in the casing 37 by a shaft 46 extending along the axis of the casing. The pen holder includes a spring clip 47 adapted to receive a fountain pen P therein and a generally trough-shaped member 48 extending perpendicularly to the axis of the shaft 46 and carrying at one end a socket 49 formed of rubber or other suitable soft and resilient material having an opening 50 therein adapted to receive the writing end of the pen P. The member 48 preferably has upstanding sides 51 adjacent the clip 47 for maintaining the latter in the desired position with respect to the member 48. The member 49 also preferably extends on the opposite side of the axis of rotation from the end which carries the socket member 49 to beyond the rear end of the pen P to provide a counterbalance for the socket-carrying end of this member. The member 48 and the clip 47 are secured to the end of the shaft in a suitable manner as by a screw 53.

The shaft 46 has a reduced portion 55, which may be constituted by a separate member force-fitted into the forward shaft portion, journaled in a needle bearing 56 force-fitted into a bearing sleeve 57 which is soldered or otherwise suitably secured to the rear member 40 and which

extends into an opening 58 in the mounting block 41. The shaft portion 55 is journaled in a needle bearing 59 force-fitted into a suitable recess 60 formed in the door 24.

The shaft 46 is adapted to be rotated by manual operation by the operator and to this end a driving mechanism is provided whereby relatively rapid rotation of the shaft may be accomplished. For this purpose a driven pulley 61 is secured to the shaft portion 55 as by a set screw 62 and is driven by a belt 63 trained over a driving pulley 64 of substantially greater diameter than the driven pulley 61. The driving pulley 64 is secured to a shaft 65 as by a set screw 66. The shaft 65 extends perpendicularly through the door 24 and is journaled in a needle bearing 67 press-fitted in the door 24 and projecting rearwardly therefrom. An actuating crank 68 is secured to the shaft 65 as by a screw 69.

It will be seen from the foregoing that rotation of the shaft 46 and consequent rotation of the pen holder 45 about the axis of the shaft 46 may be readily accomplished by actuation of the crank 68 by the operator. The turning of the crank 68 rotates the shaft 65 and in turn the pulley 64 carried thereby. This, through the belt 63, rotates the shaft portion 55 which rotates the shaft 46.

When the pen P is rotated in the manner above described, ink is expelled by centrifugal force from the writing end of the pen and, if the door 24 is closed so that the pen holder is in its proper operating position, the ink impinges against the zone 38 of the window member 31 which is radially outwardly opposite the path of movement of the writing end of the pen and which forms a portion of the trough as well as against the ring 33. The ink which thus impinges against the window member 31 drains downwardly into the trough-like space between the lower portion of the ring 33 and the horizontally opposite portion 38 of the window member 31 from whence it passes through a drain hole 70 provided in the ring 33. Disposed under the drain hole 70 is a drainpipe 71 secured in the top member 14 and having its upper end appropriately shaped to receive all the ink passing through the drain hole. Disposed under the drainpipe 71 is a suitable collecting receptacle 72 such as an ink bottle which is seated in the socket 18 in the floor whereby the receptacle is maintained in proper position under the drainpipe 71.

In order to assist in draining ink which has impinged against the window member 31, a plurality of concentric circular grooves 73 preferably are formed, as by molding or etching, in the inner surface of the window member 31 throughout the zone 38 against which ink is apt to impinge. A circular flange or baffle 74 preferably is formed integrally with the window member 31 and projects rearwardly from the inner face thereof in position to prevent ink from impinging against the window member on a portion thereof forwardly of the normal zone of impingement of the ink. Thus the portion of the window member 31 forwardly of the zone of normal impingement is maintained clear and transparent so that the cleaning operation may be readily observed and there is no detracting from the attractive appearance of the display. Preferably the zone 38 of the window member 31 rearwardly of the flange 74 is coated with colored lacquer, so that the ink or ink residue which lodges therein is concealed from the observer. It should be ex-

plained at this point that all of the inner surfaces of the members which define the ink trough and against which ink impinges when expelled from the pen are so located relatively to each other and have such shapes that the ink which rebounds therefrom is directed against another of such surfaces. Thus all of the ink which is expelled from the pen is retained within the trough and does not spatter against portions of the device outside the trough.

In using the device to clean a fountain pen, the door 24 is swung open, after releasing the latch 25, which swings the rear wall member 40 as well as the pen holder away from the cooperating ring and renders the pen holder readily accessible. A pen is inserted in the holder by introducing the writing end into the socket 50 and forcing the body of the pen into the spring clip 47. The door 24 is then closed, which action swings the pen holder and pen carried thereby into position within the cleaning chamber 37. The crank 68 is rotated, which rotates the pen about the axis of the shaft 46 and centrifugally expels from the pen any ink which may remain therein. The ink thus expelled is drained from the casing in the manner above described and deposited in the receptacle 72. If it is desired to flush the pen it is removed from the holder and water or other flushing liquid is drawn into the pen by actuation of the filling mechanism of the pen. The pen is thereafter inserted in the holder and again introduced into the cleaning chamber 37 and rotated to expel the flushing liquid, whereafter the pen may be removed and is substantially emptied of all flushing liquid.

Referring now particularly to Figs. 5 and 6, there is illustrated another embodiment of my invention which is generally similar in construction and operation to that hereinabove described but which differs from the previously described embodiment in certain constructional details which will now be described. It will be understood that where the second embodiment is not described in detail it is similar to the previously described embodiment.

In the embodiment of the invention illustrated in Figs. 5 and 6, the cabinet preferably is generally similar to the cabinet illustrated in Figs. 1 to 3 inclusive and described in connection therewith, except, however, that the floor member (not shown) is adapted to carry only bottles of ink and cleaning liquid and does not support the ink-collecting receptacle 72. Instead, the receptacle 72 is carried in a shelf-like rack 80 mounted on the inner face of the rear door 31 at the lower portion thereof. The rack 80 is formed with a socket 81 open on three sides, except at its extreme bottom portion, to permit ready insertion of the bottle 72, and a bail 82 is pivoted to the rack 80 adjacent the top of the socket to aid in retaining the bottle 72. The top member 70 is suitably cut away as at 89 to permit the rack to be positioned suitably, as shown in Fig. 5. With this arrangement the receptacle is swung out of the cabinet, when the door is opened, for a purpose which will hereinafter appear.

The upstanding portion of the cabinet is provided with a dome-shaped window member 92 in a manner generally similar to the window member 31 except that the window member 92 is of simple dome shape and preferably does not extend rearwardly beyond the opening 93 in which it is located and does not form any portion of the trough. The window member 92 is secured

in position by a plurality of metal clips 84 secured to the inner face of the front wall member 85 as by screws 86.

Cooperating with the window member 82 to define a cleaning chamber 90 is a circular partition or baffle member 91 which for convenience in manufacture preferably is constituted by a dished circular member 92 and an annular ring member 93, both of which preferably are formed of metal. The member 92 is secured as by soldering to a mounting plate 94 attached as by screws 95 and 96 to a mounting bracket 97, which screws 95 and 96 also extend through the door 81 for securing the plate 94 and bracket 97 thereto. Spacing bushings 98 are provided on the screws 95 and 96 respectively for spacing the plate 94 and bracket 97. The member 92 preferably is formed with a series of concentric, circular steps 100 for the purpose of stiffening the member and providing an attractive appearance.

At its periphery the member 92 is provided with an annular rim or flange 101 adapted to telescopingly receive a circular flange portion 102 of the member 93. The body portion of the latter is of generally conical form which, when the member 91 is in the position shown in Fig. 5, extends into the window member 82 and is located closely adjacent the rim of the latter. The member 93 is formed with an inturned lip 104 surrounding the forward opening in this member. The member 93 and the adjacent portions of the member 91 thus together provide a trough shaped and positioned to receive and retain all of the ink which is expelled from the pen.

A pen holder 110 is rotatably mounted in the chamber 90 by a shaft 111 journaled in a bearing sleeve 112 which extends through and is secured in the mounting plate 94 as by peening over the projecting end 113 of the sleeve 112. The shaft 111 also has a bearing in the mounting bracket 97 to aid in maintaining its alignment.

The pen holder 110 which is secured to the outer end of the shaft 111 as by a screw 114 includes a metal strip formed at one end to provide a trough-shaped seat 115 for the writing end of the pen P. At this end the pen holder is provided with a ring 116 serving to retain the pen against the seat and against displacement. Inwardly of the end of the pen holder 110 a ring 117 is provided which is somewhat larger than the ring 116 and is adapted to receive the body of the pen therein. A leaf spring 118 is secured to the pen holder strip adjacent the ring 116 and extends in an inward direction along the member with a portion inclined away from the member and adapted to resiliently urge the pen body against the ring 117 for yieldably holding the pen in position. At the end of the strip opposite the ring 116 a counterweight 119 is attached for counterbalancing the weight of the opposite end of the holder and of the pen carried thereby.

It will be noted that the pen holder 110 is of such form and arrangement that when the pen P is disposed therein in normal position the pen is inclined slightly to the axis of rotation of the shaft 111; however, the writing end of the pen is disposed a substantial distance outwardly of such axis. It will also be noted from inspection of Fig. 5 of the drawings that the writing end of the pen is disposed within the trough formed by peripheral portion of the partition member 91 and the ring 93 whereby when the pen is rotated ink or other liquid which is ejected from the writ-

ing end of the pen impinges against the interior surface of the trough. The conical body 103 and the inturned lip 104 serve as a baffle to prevent any ink from spattering against the window member 82 or the adjacent interior portions of the cabinet. Ink which impinges against the walls of the trough drains downwardly and is collected in the bottom portion thereof, from whence it flows through a drain hole 120 provided in the bottom portion of the member 92 and is collected in the receptacle 72.

Suitable driving means are provided for rotating the shaft 111, which means in the present embodiment of the invention include a gear drive instead of a belt drive as illustrated in connection with the previously described embodiment. The gear drive includes a driven gear 125 secured on the shaft 111 at the portion thereof which extends between the mounting plate 94 and the bracket 97. A driving gear 126 of substantially greater diameter than the driven gear 125 is secured on a shaft 127 journaled in the mounting plate 94 and bracket 97 and extending through an opening 128 in the door 81. The driving gear 126 is positioned between the plate 94 and bracket 97 by its hub 129 and a spacing collar 130. Secured to the end of the shaft 127 which projects through the door 81 is a crank 131 for rotating the shaft 127.

From the foregoing it will be seen that the second described embodiment of the invention operates in a manner generally similar to the first described embodiment. However, it will be noted that the member 91 provides in effect a self-contained receptacle for confining and collecting the ink ejected from the fountain pen and the window member 82 serves only as a closure element for closing the opening in the front wall 85 of the cabinet. The member 91 as well as the receptacle 72 are swung out of the cabinet when the door 81 is opened. By reason of the construction of the member 91, no ink is permitted to impinge upon the window member 82. However, in order to conceal the member 93, the adjacent peripheral zone of the window member 82 may be frosted or painted.

In both forms of the invention all of the metal surfaces of the pen holder, or at least those surfaces adapted to contact the fountain pen, preferably are flocked with rayon or other suitable soft material in order to prevent marring or scratching the polished surface of the fountain pen. The drive ratio of the driving mechanism is selected so that when the crank is manually operated at a speed which is comfortable and convenient to the operator, the writing end of the pen is caused to travel at a velocity sufficient to cause all of the ink or other liquid to be expelled from the pen but insufficient to cause spattering of the ink. It has been found that a drive ratio of from about 3 to 1 up to about 5 to 1 provides a desired velocity where the crank is rotated at a comfortable speed of for example around 30 up to around 35 R. P. M.

The device of the present invention preferably is so constructed as to provide a neat and attractive appearance which will add to the value of the device as a display. Thus, the metal surfaces which can be observed through the window, as for example the surfaces of the members 40 and 91, are polished and lacquered. Moreover, the bezel ring is suitably finished as by enameling or bronzing to present an attractive but unobtrusive appearance. The exposed surfaces of the

cabinet are stained and varnished or otherwise suitably finished.

It will be seen from the foregoing that the present invention provides a pen-cleaning device which not only has great utility for use in cleaning fountain pens but also has substantial value as an attention-attracting display. The customer or prospective customer is able to observe the fountain pen while it is being whirled to eject ink or cleaning liquid therefrom and his attention is focused upon the pen while it is being whirled. The advantages of an active display device of this character as contrasted to a passive display are so well known as to require no detailed discussion. The pen holder being mounted on the door, which may be swung to a fully open position, is readily accessible to the operator and thus a pen may be inserted in or removed from the holder quickly, conveniently and without danger of impairing or marring the pen. Moreover, since all of the driving mechanism is also mounted on the door, both the holder and driving mechanism may be constructed as a self-contained unit.

The device is one which can be economically and easily constructed and assembled and requires no particular skill upon the part of the operator in view of the simplicity of operation. The driving mechanism is such that it permits the pen to be rotated about an axis with the writing end traveling at a substantial linear velocity sufficient to eject by centrifugal force substantially all of the ink or cleaning liquid which may be held within the pen, even where the pen is one of the type having a capillary type ink collector.

The arrangement of the ink receiving trough insures against spattering of ink against other portions of the display or against the observer. The ink is conveniently channeled to a small receptacle which can be readily removed and emptied from time to time. The central portion of the window in the first form of the invention and the entire window in the second form play no part in catching ink expelled from the pen inasmuch as the trough is so designed that all of the ink is retained therein, as explained hereinbefore. The cabinet not only serves as an enclosure for the cleaning mechanism but also as a convenient means for mounting the various bottles of ink and cleaning liquids which are employed in cleaning pens and in changing from one type of ink to another. Moreover, the device not only serves as an active display of the pen being cleaned but also permits the display of other merchandise such as bottles of ink.

I claim:

1. A device for centrifugally expelling ink or other liquid from a fountain pen comprising a fountain pen holder, means mounting said holder for rotation about an axis and in a position to support a fountain pen on said holder with its writing end extending outwardly away from said axis, a casing substantially enclosing said holder and at least a portion of said mounting means, and including a relatively fixed section and a relatively movable section, and common movable supporting means supporting said holder, mounting means and relatively movable casing section for movement as a unit away from said relatively fixed section to render said holder accessible for attachment or removal of a fountain pen.

2. A device for centrifugally expelling ink or other liquid from a fountain pen comprising a holder for a fountain pen, means mounting said holder for rotation about an axis and in a position

to support a fountain pen carried thereby with its writing end extending outwardly from said axis; mechanism for rotating said holder, a cabinet enclosing said holder mounting means and a portion of said mechanism and including a wall having a transparent portion positioned to expose said holder to view and a partition member disposed in said cabinet and forming with said wall a casing substantially enclosing said holder and at least a portion of said mounting means.

3. A device for centrifugally cleaning a fountain pen, said device comprising a casing defining a substantially vertically positioned chamber, means for mounting the pen to be cleaned in the chamber, said chamber adapted to collect the fluid discharged from the pen in the cleaning operation, said mounting means being adapted for supporting the fountain pen substantially vertically for rotation about a transverse axis with the point of the pen contiguous to a portion of the outer periphery of the chamber surrounding the axis during the cleaning operation, and means for rotating said mounting means whereby the fluid within the pen is centrifugally ejected, said chamber having an opening in its lower portion for discharging the ejected fluid.

4. A device for centrifugally cleaning a fountain pen, said device comprising a casing defining a chamber inclined to the horizontal, means for mounting the pen to be cleaned in the chamber, said chamber formed with an annular recess adapted to collect the fluid discharged from the pen in the cleaning operation, said mounting means being adapted for vertically supporting the fountain pen substantially in a plane intermediate the front and rear ends of the chamber whereby the pen is adapted to eject the fluid within the chamber as said last-mentioned means is rotated, means operatively connected to said mounting means for rapidly rotating the fountain pen whereby the fluid within the pen is centrifugally ejected into the aforesaid annular recess, means adapted to discharge the fluid from the aforesaid recess, and means for receiving the fluid drained from the recess.

5. A device for cleaning fountain pens comprising a chamber inclined to the horizontal and adapted for mounting a pen to be cleaned therein, said chamber comprising a fixed wall surface and a movable wall surface, said chamber formed with an annular recess adapted to collect the fluid discharged from the pen in the cleaning operation, means adapted for supporting the fountain pen substantially in a plane intermediate the front and rear end of the chamber whereby the pen is adapted to eject fluid within the chamber as said last-mentioned means is rotated, means for rotatably mounting the pen supporting means on the movable wall surface of the chamber, said movable wall surface adapted when separated from the chamber to permit the attaching and detaching of the fountain pen to the pen supporting means, and in the closed position of the movable wall surface with the fountain pen positioned within the chamber permitting rotation of the fountain pen whereby the fluid within the fountain pen is ejected.

6. A device for cleaning fountain pens comprising a chamber inclined from the vertical and adapted for mounting a pen to be cleaned therein, said chamber comprising a transparent wall surface and a reflecting rear wall surface, one of said surfaces adapted to be movable whereby the fountain pen to be cleaned may be positioned

within the chamber, said chamber formed with an annular recess adapted to collect the fluid discharged from the pen in the cleaning operation, means adapted for rotatably supporting the fountain pen substantially in a plane intermediate the front and rear end of the chamber, means for detachably mounting the pen on the pen supporting means, and means for rotating the pen supporting means whereby the fluid within the fountain pen is centrifugally ejected.

7. A display device for accessories for a fountain pen comprising a cabinet structure including a base and an upwardly inclined housing adapted to receive a device for cleaning fountain pens, said device for cleaning fountain pens comprising a casing defining a chamber mounted within the upwardly inclined housing and including a transparent front wall therefor and a reflecting rear wall surface, said transparent wall surface permitting the cleaning operation to be observed therethrough and through an opening in the upwardly inclined housing, one of said surfaces being movable whereby the fountain pen to be cleaned may be positioned within the chamber.

8. A display device for accessories for a fountain pen comprising a cabinet structure including a base and an upwardly inclined housing adapted to receive a device for cleaning fountain pens, said upwardly inclined housing including a front transparent wall surface and a movable rear closure member, said device for cleaning fountain pens including a chamber, one wall of said chamber formed by the aforesaid transparent wall surface of the housing, said chamber including a rear wall surface, means for supporting the fountain pen substantially in a plane intermediate the front and rear ends of the chamber on said rear wall surface, said rear wall surface of the chamber and the movable rear wall closure for the housing being affixed together, whereby, as the closure for the housing is opened the rear wall surface of the chamber is moved to a position enabling mounting and dismounting of a fountain pen to be cleaned on said supporting means.

9. A display device for accessories for a fountain pen comprising a cabinet structure including a base and an upwardly inclined housing adapted to receive a device for cleaning fountain pens, said upwardly inclined housing including a front transparent wall surface and a movable rear closure member, said device for cleaning fountain pens including a chamber adapted to receive the fountain pen, one wall of said chamber formed by the aforesaid transparent wall surface of the housing, said chamber including an annular recess adapted to receive the fluid discharged from the fountain pen during the cleaning operation, said chamber including a rear wall surface, one of said wall surfaces of said chamber being movable whereby the fountain pen is adapted to be positioned within the chamber, means for supporting the fountain pen substantially in a plane intermediate the front and rear end of the chamber, means for rotating said supporting means, said rotating means being positioned intermediate the rear wall surface of the chamber and the movable rear closure member, means operatively connected to the rotating means extending exteriorly of the housing, and said rear wall surface of the chamber and the movable rear closure member being movable together, whereby, as the housing is opened and closed, the chamber is opened and closed per-

mitting the mounting and dismounting of a fountain pen to be cleaned within the chamber.

10. A device for centrifugally cleaning a fountain pen comprising a chamber adapted for mounting the pen to be cleaned therein, said chamber comprising a front transparent wall surface and a rear wall surface, one of said surfaces being movable for permitting the mounting of a fountain pen within the chamber, means adapted for rotatably supporting the fountain pen to be cleaned in a plane within the chamber, means for resiliently clamping the fountain pen on said supporting means, whereby the fountain pen is positioned to discharge fluid outwardly against the outer periphery of the chamber, said chamber adapted to receive the discharged fluid, said fountain pen and said supporting means being substantially counterbalanced in the operating position, means for rotating said supporting means, and drive means interconnecting said rotating means and supporting means for rotating the supporting means at a greater rate of speed than said rotating means.

11. A device for centrifugally cleaning a fountain pen comprising a chamber adapted for mounting the pen to be cleaned therein, said chamber comprising a front transparent wall surface and a rear wall surface, one of said surfaces being movable permitting the mounting of a fountain pen within the chamber, means adapted for rotatably supporting the fountain pen to be cleaned in a plane intermediate the front and rear wall surfaces of the chamber, said chamber having a recess adapted to receive the fluid discharged from the fountain pen formed contiguous to the front wall surface and intermediate the front and rear wall surfaces of the chamber, said recess adapted to discharge the fluid collected in the recess to a receptacle exteriorly of the chamber, said supporting means being adapted to be counterbalanced by means of the fountain pen mounted therein, and drive means operatively connected to said supporting means, whereby a fountain pen mounted on said supporting means is rapidly rotated centrifugally ejecting any fluid retained within the pen, causing the fluid discharged to be collected in the recess and discharged therefrom during the cleaning operation.

12. A device for centrifugally cleaning a fountain pen comprising a chamber adapted to receive the fountain pen for rapid rotation therein, a movable wall portion for the chamber whereby a fountain pen to be cleaned may be positioned within the chamber, rotatable means for detachably supporting the fountain pen in the cleaning position with the point thereof contiguous to the outer periphery of the chamber, drive means for rotating said rotatable means, and common movable supporting means for supporting said drive means and movable wall portion of the chamber whereby the movable wall portion and the drive means move together in response to movement of the movable wall portion toward and from the remaining portion of the chamber in the operation of positioning of the fountain pen to be cleaned upon said rotatable means.

13. A device for centrifugally ejecting ink or other liquid from a fountain pen including a holder for the pen, means mounting said holder for rotation about an axis with the writing end of a pen in the holder outwardly of said axis, means defining a relatively stationary annular trough radially outwardly of the path of the writing end

2,628,431

13

of the pen, and a cabinet having an outwardly movable wall portion carrying said holder and mounting means on its inner side for movement of said elements into and out of said cabinet as a unit.

DAVE CHAPMAN.

Number
1,071,943
1,903,174
2,256,663
2,461,489
2,569,690

14

Name	Date
Mogni -----	Sept. 2, 1913
Ferguson -----	Mar. 28, 1933
Brewer -----	Sept. 23, 1941
Wolfskill -----	Feb. 8, 1949
Ressinger -----	Oct. 2, 1951

REFERENCES CITED

The following references are of record in the file of this patent:

Number
443,672

FOREIGN PATENTS

Country	Date
Great Britain -----	Mar. 4, 1936

UNITED STATES PATENTS

Number	Name	Date
763,487	Hinton -----	June 28, 1904