

May 9, 1933.

W. R. CUTHBERT

1,908,123

FOUNTAIN PEN CONSTRUCTION

Filed July 22, 1929

2 Sheets-Sheet 1

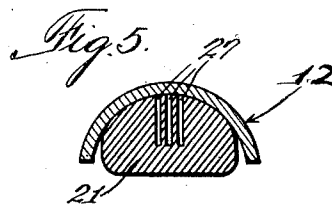
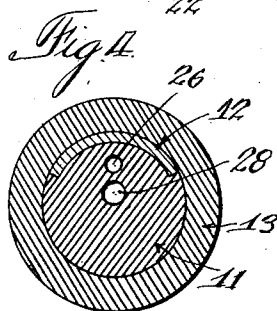
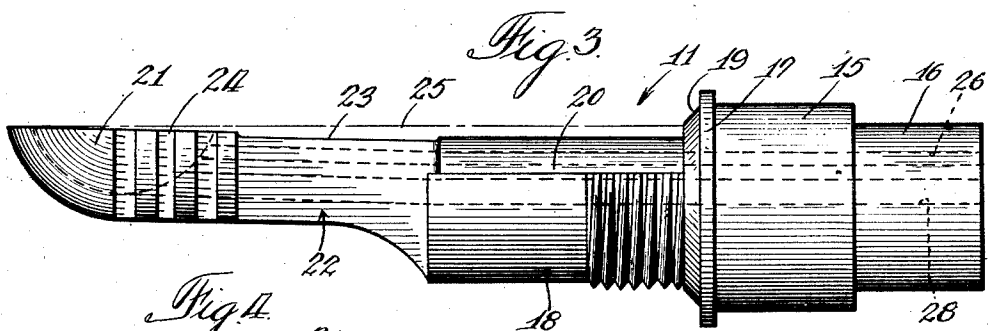
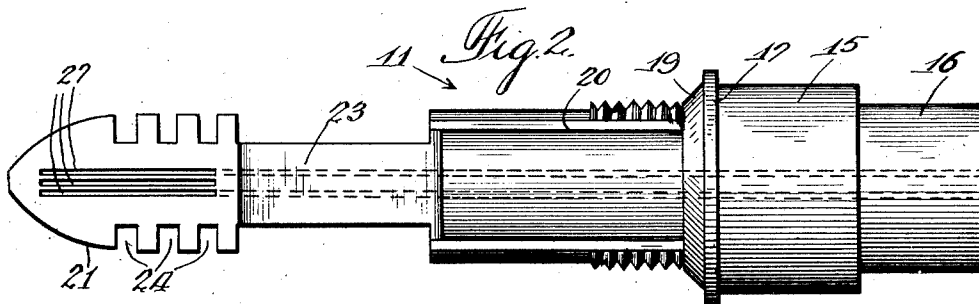
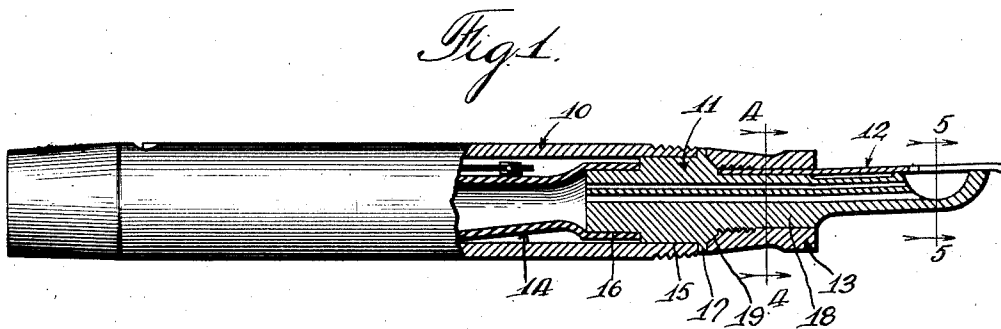

Inventor

WILLIAM R. CUTHBERT.

By Jones, Addington, Amso & Seibold.
Attys.

Witness
David S. Magnusson.

May 9, 1933.

W. R. CUTHBERT

1,908,123

FOUNTAIN PEN CONSTRUCTION

Filed July 22, 1929

2 Sheets-Sheet 2

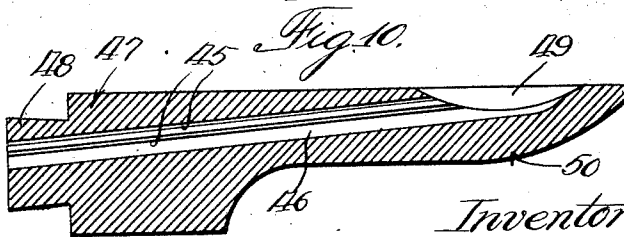
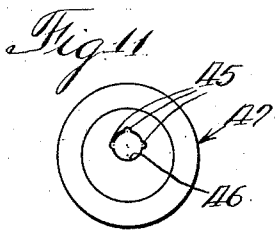
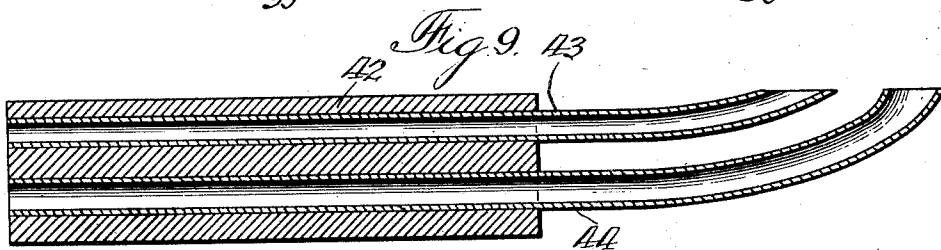
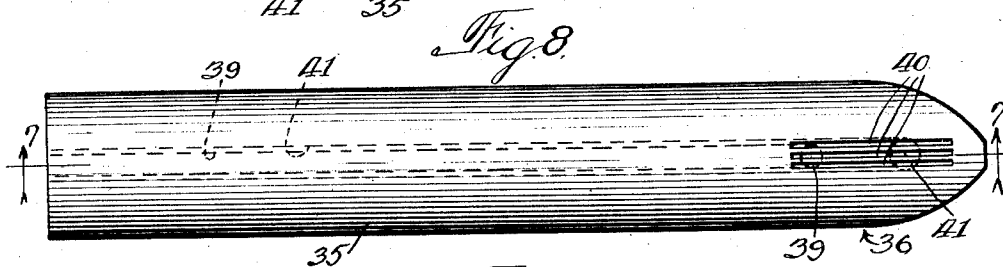
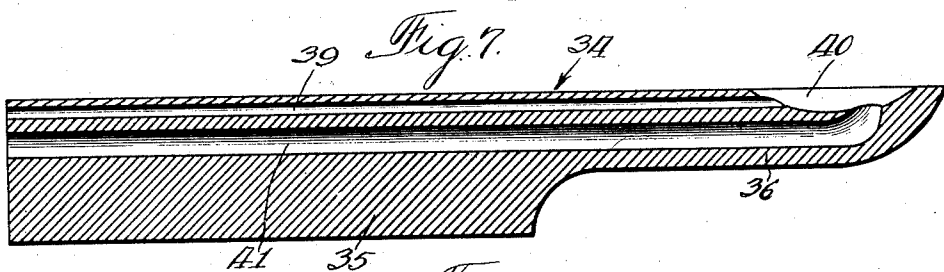
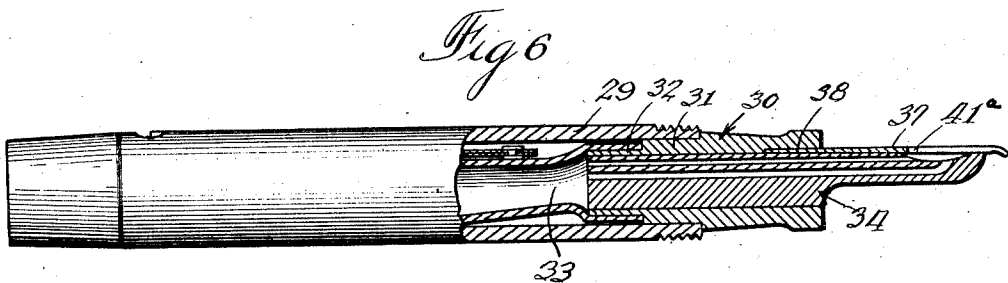

Inventor:

WILLIAM R. CUTHBERT.

By: James A. Adlington, Amos & Scribner.

Attys.

Witness:

David S. Magnusson.

UNITED STATES PATENT OFFICE

WILLIAM R. CUTHBERT, OF FORT MADISON, IOWA, ASSIGNOR TO W. A. SHEAFFER
PEN CO., OF FORT MADISON, IOWA, A CORPORATION OF DELAWARE

FOUNTAIN PEN CONSTRUCTION

Application filed July 22, 1929. Serial No. 379,958.

This invention relates to a fountain pen construction and has special reference to a fountain pen construction wherein the flow of ink is facilitated when the pen is in use and sealed when not in use and the writing point is readily removable for cleaning or repair and for access to the adjacent delicate passageways.

More particularly, this invention relates to a fountain pen construction comprising a barrel enclosing an ink sack and having an open end for receiving an ink feeding mechanism and a pen nib, the ink feeding mechanism having an air duct extending longitudinally thereof communicating between the ink sack and the heart of the pen nib, and having an ink duct likewise extending longitudinally thereof communicating between the ink sack and the outer end or adjacent the writing point of the pen nib.

In fountain pen constructions commonly employed today, the single duct for supplying ink from the ink sack to the pen nib and air to the ink sack to replace the ink is invariably choked by an air bubble large enough to cut off the supply of ink for a short period of time. This action at least causes an irregular flow of ink, sometimes too freely, thereby causing the ink to drop upon the writing surface and cause a blot thereon. When the single combination air and ink duct is of a smaller diameter the above is not unusual while when the duct is of a larger diameter to prevent a bubble from cutting off the supply, an excessive entrance of air may be introduced into the ink sack resulting in the ink dropping unhindered from the pen point to the writing surface.

Further, in providing a plurality of ducts, for example, one for the passage of ink and other for the passage of air, it has been found by experiment that a certain balance must be maintained therebetween. When the pressure is equalized in both ducts, the latter becomes choked and the ink does not flow freely from the pen. It is desirable to provide the air duct of a smaller diameter than the ink duct, as for example, in a man's pen of average size, the diameter of the air

duct is .035 of an inch and the diameter of the ink duct is .050 of an inch. These dimensions are for comparative reference only and it is to be understood that this invention is not to be limited by the figures above recited.

It is also the teaching of this invention to have the air duct terminate at one end thereof adjacent to the heart of the pen nib, the other end of the duct extending longitudinally of the feeding mechanism to the end thereof to communicate with the ink sack. The ink duct terminates at one end thereof between the heart of the nib and the writing point, the other end extending longitudinally of the feeding member to the end thereof to communicate with the ink sack attached thereon.

The pen nib is readily removed by providing a collar to engage the ink feeding member at the outer periphery thereof, the pen nib being seated in a cut-away portion of the periphery and held in place by the collar. The nib engaging portion of the ink feeding member is tapered all along the portion extending from the collar in a direction toward the pen nib. A seal is thereby effected by reason of a tight engagement between the end of the tapered portion and the somewhat resilient pen nib.

One of the objects of the present invention is to provide a fountain pen construction wherein the flow of ink is facilitated by the provision of an air duct between the ink sack and the heart of the pen nib and an ink duct between the ink sack and a point between the heart of the pen nib and the writing point thereof, the ink duct being of a larger diameter than the air duct.

Another object of this invention is to provide a fountain pen construction in which the pen nib is readily removable for the cleaning and the repair thereof and of the adjacent ink feeding passageways.

Another object of this invention is to provide a fountain pen construction in which the ink is sealed in the ink feeding mechanism by reason of a tapered engaging portion engaging the pen nib at the outer ends thereof.

Further objects and advantages will hereinafter be more fully pointed out and for a more complete understanding of the nature, scope and characteristics of this invention, reference may now be had to the following description when taken together with the accompanying drawings, in which latter:

Figure 1 is a side view partially in section of the fountain pen construction embodying one embodiment of this invention;

Fig. 2 is a plan view of the ink feeding member shown in Figure 1;

Fig. 3 is a side elevational view of Fig. 2;

Fig. 4 is a vertical sectional view taken on the line 4—4 of Figure 1;

Fig. 5 is a vertical sectional view taken on the line 5—5 of Figure 1;

Fig. 6 is a side view partially in section of a fountain pen construction embodying another form of ink feeding mechanism;

Fig. 7 is a central longitudinal sectional view of the ink feeding members of Fig. 6;

Fig. 8 is a top plan view of the member illustrated in Fig. 7;

Fig. 9 is a central longitudinal sectional view of a third form of ink feeding mechanism embodying the principles of this invention;

Fig. 10 is a central longitudinal sectional view of still another form of ink feeding mechanism; and

Fig. 11 is an end elevational view of the member illustrated in Fig. 10.

Referring now to the drawings and more particularly to Figs. 1 to 5, inclusive thereof, the construction embodying the features of this invention comprises a barrel 10 having an open end for receiving an ink feeding member 11, the latter supporting at one end thereof a pen nib 12 secured thereto by means of a collar 13 and at the other end thereof an ink sack 14.

The ink feeding mechanism 11 is preferably formed of a composition material and comprises an elongated member having a portion 15 of circular periphery for snugly engaging the bore of the barrel 10. A reduced portion 16 thereof extends interiorly of the bore of the barrel 10 and receives one end of the sack 14, the sack being normally of a substantially smaller diameter than the diameter of the extension 16 whereafter it is stretched to extend around the extension 15 in a liquid-tight relation therewith. The barrel engaging portion 15 is provided further with an annular flange 17 to engage the end of the barrel 10 thereby to position the ink feeding mechanism on the barrel and to prevent displacement thereof into the bore of the barrel. A reduced portion 18 extends outwardly from the flange 17, the flange having a converging shoulder 19 formed therefrom extending to the reduced portion 18 to act as a seat for the collar 13. The reduced extension 18 is

provided with external threads to engage internal threads of the collar 13.

The upper portion of the extension 18 (as viewed in Fig. 3) is provided with a cut-away portion or recess 20 peripherally and extending the full length thereof to the seat 19 to receive one end of the pen nib 12. It is apparent that when the collar 13 is threaded into engagement with the threads of the extension 18 that the pen nib 12 is securely held in position therewith. The outer end of the ink feeding mechanism 11 is provided with a head 21 which is formed preferably integrally with the portions 15, 16 and 18 by an intermediate neck portion 22. The neck portion 22 is cut away at the sides thereof (as viewed in Fig. 2) and on the upper face surface 23, the head portion 21 thereby extending a slight distance above the surface 23.

The surface 24 of the head portion 21 is tapered in a direction outwardly and upwardly in Fig. 3 of the drawings in order to provide a snug engagement with the end of the pen nib 12. When the pen nib is tightened in its recess in the extension 18 the outer end of the pen nib is forced upwardly a slight distance by the head 21 engaging therewith. This action will be apparent upon viewing the showing in Fig. 3 of the drawings wherein the horizontally extending dot and dash line 25 shows the end portion or tip of the head 21 a substantial distance above the periphery of the portion 18 at the recess 20 thereof.

The ink feeding mechanism is provided with an air duct 26 extending longitudinally thereof and communicating between the ink sack 14 and the fissures 27 broached in the head portion 21. The air duct 26 is preferably drilled through the ink feeding mechanism and extends from one end thereof to the periphery of the semi-circularly shaped fissures 27, the duct being disposed but a slight distance inwardly of the periphery of the ink feeding mechanism whereby the air duct 26 meets the circumferential portion of the semi-circular fissures near the diametrical portion thereof.

An ink duct 28 extending longitudinally of the ink feeding member communicates between the ink sack and the fissures 27. This duct is preferably drilled through the material of the ink feeding member and is disposed interiorly a substantial distance from the periphery thereof so that the base of the duct, as viewed in Fig. 3, extends substantially tangentially to the circular periphery of the fissures from a radius disposed at right angles to the base 24. The air duct 26 is, therefore, disposed in the material of the ink feeding member between the ink duct 28 and the pen nib engaging periphery of the ink feeding member.

As hereinbefore stated, the air duct is sub-

stantially smaller in diameter than the ink duct, a ratio of approximately three and one-half to five. By reason of the balance between the supply of air to the ink sack and the demand for the ink at the writing point together with the positioning of the ducts within the ink feeding member and point of contact with the pen nib, the flow of ink is greatly facilitated and a smooth operation is assured. Further, by reason of the collar 13 being removable, the pen nib 12 may be removed readily and the fissures 27 cleaned as well as the underneath side of the pen. Again, since the surface 24 for engaging the pen nib 12 is tapered and the surface 23 of the neck portion 22 is recessed, a seal is affected at the outer end of the pen nib until pressure is brought to bear thereon when in use to permit the seal to be broken.

Referring now more particularly to Figs. 6 to 8, inclusive, of the drawings the construction therein comprises a barrel 29 having a neck portion 30 inserted in the open end thereof, the portion 31 of the neck being of a circular periphery and snugly engaging the inner bore of the barrel 29. A reduced extension 32 formed interiorly of the barrel on the portion 31 receives the end of an ink sack 33 in liquid-tight engagement therewith, the diameter of the end of the ink sack normally being substantially less than the diameter of the portion 32 whereby it is extended to fit there around. The neck portion is provided with a shoulder to fit against the end of the barrel 29 to prevent displacement interiorly thereof.

The neck portion 30 is provided with an axially and longitudinally extending aperture for receiving an ink feeding member 34, which latter comprises a portion 35 of circular cross section and a portion 36 of substantially semi-circular cross section. A pen nib 37 is disposed on the upper surface (as viewed in Fig. 6) of the semi-circular extending portion 36 and partly over the portion 35 of the circular cross section, the upper surfaces being contiguous and the neck 30 being recessed interiorly as at 38 to receive the pen in snug engagement.

An air duct 39 is provided longitudinally of the ink feeding member and communicates between the ink sack 33 and the near end of the fissures 40, which latter are adjacent the outer end of the ink feeding member. An ink duct 41 is provided longitudinally of the ink feeding member 34 and communicates between the ink sack 33 and the far end of the fissures 40. In practice the air duct meets the arcuate periphery of the fissures 40 at a point immediately adjacent to the heart 41a of the pen nib and the ink duct 41 meets the circular periphery of the fissures 40 at a point between the heart 41a of the pen nib and the writing point there-

of. This construction provides a path of travel for the air and ink conducive to the proper flow of the ink to the writing point, the air entering the heart 41a and passing through the duct 39 to the ink sack to take the place of the ink passing downwardly through the duct 41 to the writing point. The ink duct 41 is substantially larger in diameter than the air duct 39 in order to provide a pressure in both ducts for the balance that must be maintained therebetween for a proper flow of ink.

Referring now more particularly to Fig. 9 the ink feeding mechanism comprised therein is formed of a rod member 42 having apertures extending longitudinally there-through from one end to the other, the apertures receiving tubular members 43 and 44. The tubular member 43 is of a smaller diameter than the tubular member 44 and both of the members extend a substantial distance outwardly from one end of the rod member 42, the open ends being turned upwardly to be terminated in a horizontal plane substantially tangentially to the periphery of the rod member 42. The tubular member 43 communicates between the ink sack and the heart of the pen to supply air to the ink sack, as in the previously described embodiments, and the ink from the ink sack is drawn downwardly by capillary attraction to the pen nib at a point between the heart of the pen and the writing point. The flow of ink is facilitated in the same manner as in the previously described modifications.

Referring now more particularly to Figs. 10 and 11 of the drawings a further modification is shown wherein the air ducts are in the form of fissures 45 broached in the upper walls of the aperture or passageway 46. The aperture 46 extends longitudinally through the ink feeding member 47 and communicates between the ink sack attached to the reduced extension 48 and the fissures 49 in the tip portion 50. The fissures 45, being broached on the upper periphery of the aperture 46, will meet the fissures 49 at a point near the forward end thereof. The aperture 46 extends substantially the entire length of the fissures 49 wherefore the ink passing through the passageway 46 will be conducted to a point adjacent the writing point end of the pen nib and the air will be conducted from the heart of the pen nib to the ink sack.

While several embodiments of this invention are herein shown and described, it is to be understood that various modifications may be apparent to those skilled in the art without departing from the spirit and scope of this invention and, therefore, the same is to be limited only by the scope of the prior art and the appended claims.

What I claim is:

1. A fountain pen construction including

70

75

80

85

90

95

100

105

110

115

120

125

130

a pen nib having a heart pierce, an ink feeding mechanism having separate ink and air ducts communicating between the ink reservoir and said pen nib, said air duct terminating at said heart of said pen nib and said ink duct terminating adjacent said pen nib between the heart and the writing point thereof.

2. A fountain pen construction including a pen nib having a heart pierce, an ink feeding mechanism having ink and air ducts communicating between the ink reservoir and said pen nib, said air duct being smaller in diameter than said ink duct and terminating at said heart of said nib, said ink duct terminating adjacent said nib between the heart and the writing point thereof.

3. A fountain pen construction including an ink feeding mechanism having ink and air ducts communicating between the ink reservoir and the pen nib of said fountain pen, the pen nib engaging surface having fissures extending therefrom to communicate with said ducts, said ducts meeting said fissures at different points thereon.

4. A fountain pen construction including an ink feeding mechanism having ink and air ducts communicating between the ink reservoir and the pen nib of said fountain pen, the pen nib engaging surface having fissures of semi-circular contour extending therefrom to communicate with said ducts, said air duct meeting said fissures on the circumferential portion thereof adjacent the diametrical portion and said ink duct meeting said fissures on the circumferential portion thereof substantially tangentially a radius at right angles to said diametrical portion.

In witness whereof, I have hereunto subscribed my name.

WILLIAM R. CUTHBERT.

45

50

55

60